



DEVELOPMENT STANDARD

QIC-140
Revision A
26 Feb 92

READ-ONLY UNRECORDED MAGNETIC TAPE MINICARTRIDGE FOR INFORMATION INTERCHANGE

0.25 inch (6.35 mm), 3.5-inch form factor
10 000–14 700 ftpi (394–579 ftpmm)
550 Oersteds (44 000 amperes/meter)

**Quarter-Inch
Cartridge
Drive Standards, Inc.**

311 East Carrillo Street
Santa Barbara, California 93101
Telephone (805) 963-3853
Fax (805) 962-1541
www.qic.org

(See important notices on the following page)

Important Notices

This document is a development standard adopted by Quarter-Inch Cartridge Drive Standards, Inc. (QIC). This document may be revised several times during the development cycle. It is intended solely as a guide for companies interested in developing products which can be compatible with other products developed using this document. QIC makes no representation or warranty regarding this document, and any company using this document shall do so at its sole risk, including specifically the risks that a product developed will not be compatible with any other product or that any particular performance will not be achieved. QIC shall not be liable for any exemplary, incidental, proximate or consequential damages or expenses arising from the use of this document. This development standard defines only one approach to the product. Other approaches may be available in the industry.

This development standard is an authorized and approved publication of QIC. The underlying information and materials contained herein are the exclusive property of QIC but may be referred to and utilized by the general public for any legitimate purpose, particularly in the design and development of quarter-inch tape cartridge drive subsystems. This development standard may be copied in whole or in part *provided* that no revisions, alterations or changes of any kind are made to the materials contained herein. Only QIC has the right and authority to revise or change the material contained in this development standard, and any revisions by any party other than QIC are totally unauthorized and specifically prohibited.

Compliance with this development standard may require use of one or more features covered by proprietary rights (such as features which are the subject of a patent, patent application, copyright, mask work right or trade secret right). By publication of this development standard, no position is taken by QIC with respect to the validity or infringement of any patent or other proprietary right, whether owned by a Member or Associate of QIC, or otherwise. QIC hereby expressly disclaims any liability for infringement of intellectual property rights of others by virtue of the use of this development standard. QIC has not and does not investigate any notices or allegations of infringement prompted by publication of any QIC development standard, nor does QIC undertake a duty to advise users or potential users of QIC development standards of such notices or allegations. QIC hereby expressly advises all users or potential users of this development standard to investigate and analyze any potential infringement situation, seek the advice of intellectual property counsel, and, if indicated, obtain a license under any applicable intellectual property right or take the necessary steps to avoid infringement of any intellectual property right. QIC expressly disclaims any intent to promote infringement of any intellectual property right by virtue of the evolution, adoption, or publication of any QIC development standard.

FOREWORD (THIS FOREWORD IS NOT PART OF THIS STANDARD)

THIS STANDARD PRESENTS THE MINIMUM REQUIREMENTS FOR THE PHYSICAL AND MAGNETIC INTERCHANGE OF A 0.25 in (6.30 mm) WIDE MAGNETIC TAPE MINI-CARTRIDGE BETWEEN INFORMATION PROCESSING SYSTEMS, COMMUNICATIONS SYSTEMS, AND ASSOCIATED EQUIPMENT UTILIZING THE STANDARD CODE FOR INFORMATION INTERCHANGE. THIS STANDARD SUPPORTS A RECORDING DENSITY OF 14,700 FTPI AND COMPLEMENTS QIC-80 FLEXIBLE-DISK-CONTROLLER-COMPATIBLE RECORDING FORMAT FOR INFORMATION INTERCHANGE (28 TRACKS 14,700 BPI, MFM, 80/120 MB).

THE QUARTER-INCH CARTRIDGE DRIVE STANDARDS, INC. (QIC), WHICH DEVELOPED THIS STANDARD, CONSISTS OF A NUMBER OF EXPERIENCED AND QUALIFIED SPECIALISTS ON THE RECORDING OF DIGITAL INFORMATION ON MAGNETIC TAPE. IN THE DEVELOPMENT OF THIS STANDARD, CAREFUL CONSIDERATION WAS GIVEN TO CURRENT PRACTICES, EXISTING EQUIPMENT AND SUPPLIES, AND THE BROADEST POSSIBLE ACCEPTANCE, AND TO PROVIDING A BASIS OF FUTURE IMPROVEMENT IN THE USE OF THE MEDIUM.

SUGGESTIONS FOR IMPROVEMENT OF THIS STANDARD WILL BE WELCOME. THEY SHOULD BE SENT TO QUARTER-INCH CARTRIDGE DRIVE STANDARDS, INC. 311 EAST CARRILLO STREET, SANTA BARBARA, CALIFORNIA, 93101, TELEPHONE (805) 963-3853, FAX (805) 962-1541.

Editor:
Dan Argento
Imation Corporation
Camarillo, CA. 93012
(805) 388-4878
E-mail: djargento@imation.com

Foreword

Contents

1 Introduction	1
1.1 Scope	1
1.2 Purpose	1
1.3 Conformance	1
1.4 Dimension	1
2 References	2
3 Definitions	2
4 Environment and safety	4
4.1 Testing environment	4
4.2 Operating environment	4
4.3 Transportation environment	5
4.4 Storage environment	5
4.5 Conditioning of the cartridge	5
4.6 Safety	5
5 Tape mechanical and electrical properties	5
5.1 Tape width and tolerance	5
5.2 Tape length	6
5.3 Tape thickness	6
5.4 Tape position holes	6
5.5 Leaders and splices	6
5.6 Tape wind	6
5.7 Tensile yield force	6
5.8 Electrical resistance	7
5.9 Layer-to-layer adhesion	7
5.10 Tape cupping	8
5.11 Tape light transmission	9
6 Tape recording properties	9
6.1 Defect density	10
6.2 Ease of erasure	11
6.3 Average signal amplitude	11
6.4 Signal decay	11
6.5 Resolution	12
6.6 Typical field	12

7 Mechanical specifications of the tape cartridge	12
7.1 General description	12
7.2 Physical label	13
7.3 Tape guides	13
7.4 Drop Test	13
7.5 Speeds	13
7.6 Driving force	14
7.7 Total inertia	14
7.8 Dynamic response	14
7.9 Tape tension	14
7.10 Drive ratio	16
7.11 Belt capstan electrical resistance	16
7.12 Instantaneous speed variation (ISV).	17
7.13 Acceleration	18
7.14 Dynamic tape skew	18
7.15 Head penetration	19
7.16 Dynamic track movement variation	19
7.17 Cartridge durability	19

Figures

1 Possible cartridge configuration	20
2 Tape position holes	21
3 Tape resistance measurement electrodes	22
4 Tape resistance measurement circuit	22
5 Cartridge dimensions	23
6 Cartridge locating planes	24
7 Light sensing	25
8 Cartridge-in-position sense.	26
9 Cartridge door profile	27
10 Label area	28
11 Tape path and drive dimensions	29
12 Tape light transmission text fixture	30
13 Tape light transmission text circuit	31
14 Transverse tape tension test rod	32
15 Belt capstan electrical resistance test fixture.	33

1 Introduction

1.1 Scope

This standard provides the information necessary to ensure mechanical and magnetic interchangeability for a tape cartridge between information processing systems, communication systems, and associated equipment. This standard provides the general requirements, definitions, physical and magnetic tape characteristics, and the cartridge requirements.

1.2 Purpose

This standard defines the requirements and supporting test methods necessary to ensure interchange at acceptable performance levels. It is distinct from a specification in that it delineates a minimum of restrictions consistent with compatibility in interchange transactions.

The performance levels in this standard represent the minimum acceptable levels that the interchange items should meet or surpass during their useful life and, thus, define end-of-life criteria for interchange purposes. The performance levels in this standard are not intended to be employed as substitutes for purchase specifications.

Wherever feasible, quantitative performance levels that must be met or exceeded in order to comply with this standard, are given. In all cases, including those in which quantitative limits for requirements falling within the scope of this standard are not stated but left to agreement between the interchange parties, standard test methods and measurement procedures shall be used to determine such limits.

1.3 Conformance

A magnetic tape cartridge conforms to this standard if it satisfies all mandatory requirements of this standard. The tape requirements shall be satisfied throughout the extent of the tape.

1.4 Dimensions The original dimensions and quantities for all numeric values in this standard are in U.S. customary engineering units (similar to British imperial units) and centimeter-gram-second electromagnetic units (cgs-emu). Conversions of these units to procedures described in American national standard metric practice, ANSI/IEEE 268-1982. Units of either of the two measurement systems may be referred to, but the two systems should not be intermixed or reconverted. Conversions of toleranced dimensions and quantities in this standard have been performed in accordance with Method A or Method B of ANSI/IEEE 268-1982 and International standard toleranced dimensions - conversions from inches to millimeters and vice versa, ISO 370:1975 as required to maintain the implied correspondence between the accuracy of the original data and the number of the significant digits and rounding of the converted values. Method A has been used to achieve economy unless a requirement for absolute assurance to fit justified the use of Method B. Conversions made in accordance with Method B are so indicated. In the national standards of ISO members bodies, additional rounding may be done to produce "preferred" values. These values should lie within or close to the original tolerance.

2 References

ANSI Y14.5M-1982 Engineering drawing and related documentation practices, dimensioning and tolerancing.

ANSI/IEEE 268-1982 Metric practice.

ISO 370:1975 Toleranced dimensions - conversions from inches into millimeters and vice versa.

UL94 Underwriters Laboratory standard for safety-test for flammability of plastic materials, parts, devices and appliances.

3 Definitions

3.1 average signal amplitude: The average peak-to-peak value of the signal output of the read head measured over a minimum of 1.0 in (25.4 mm) exclusive of dropouts.

3.2 beginning-of-tape (BOT) marker: A set of two holes punched in the tape. Three sets of holes are provided to ensure reliability of detection. The innermost set of holes identifies the storage position for the cartridge. In the storage position, all of the useable recording area shall be wound on the supply hub and protected by at least one layer of tape. Cartridges to be interchanged shall be rewound to the storage position prior to interchange.

3.3 early warning (EW) marker: One hole punched in the tape to indicate the approaching end of the useable recording area in the forward direction of tape motion. Recording must halt before the EOT marker is detected.

3.4 end of tape (EOT) marker: A single hole punched in the tape to indicate that the useable recording area when the tape is moving in the forward direction, has been exceeded. Three holes are provided along a single line, to ensure reliability of detection.

3.5 flux transition position: The point that exhibits the maximum free-space surface flux density normal to the tape surface.

3.6 in contact: An operating condition in which the magnetic surface of the tape is in physical contact with a magnetic head.

3.7 load point (LP) marker: A single hole punched in the tape to indicate the start of the useable recording area when tape motion is in the forward direction.

- 3.8 long length (LL):** Denotes tape length between LP and EW markers, see figure 2.
- 3.9 magnetic tape:** A tape which will accept and retain magnetic signals intended for input, output, and storage purposes on computers and associated equipment.
- 3.10 master standard reference tape:** A tape selected as the standard for the average signal amplitude, resolution and typical field.
- 3.11 physical recording density:** The number of recorded flux transitions per unit length of track, e.g., flux transitions per inch (ftpi) or flux transitions per millimeter (ftpmm).
- 3.12 reference field:** The typical field of the master standard reference tape.
- 3.13 resistance per square:** The surface resistance of a square area, of any size, measured between electrodes placed on two opposite sides of the square. The unit of measurement is the ohm.
- 3.14 resolution:** The ratio of the average signal amplitude measured at 10 000 ftpi (394 ftpmm) to that measured at 3333 ftpi (131 ftpmm), and the ratio of the average signal amplitude measured at 14 700 ftpi (579 ftpmm) to that measured at 4900 ftpi (193 ftpmm).
- 3.15 secondary standard reference tape:** A tape the performance of which is known and stated in relation to that of the master standard reference tape.
- 3.16 short length (SL):** Denotes tape length between LP and EW markers, see figure 2.
- 3.17 standard measurement current:** For the test physical recording density, the standard measurement current (I_M) is 1.3 times the standard reference current (I_r) at 10 000 ftpi (394 ftpmm) and 14 700 ftpi (479 ftpmm).
- 3.18 standard reference amplitude:** The average peak-to-peak signal amplitude output from the master standard reference tape when it is recorded with the standard measurement current on the reference measurement system at the test physical recording density. The signal amplitude shall be averaged over a minimum of 1.0 in (25.4 mm) of tape. Traceability to the standard reference amplitude reference level is provided by the calibrations supplied with each secondary reference tape.
- 3.19 standard reference current:** The current (I_r) that produces the reference field.
- 3.20 tested recording area:** That portion of the tape, as shown in figure 2, that has been tested in accordance with 6.
- 3.21 track:** A longitudinal area on the tape along which a series of magnetic signals may be recorded.

3.22 typical field: In the plot of average signal amplitude against the recording field at the physical recording density of 10 000 ftpi (394 ftpmm) and 14 700 ftpi (579 ftpmm) the minimum field that causes an average signal amplitude equal to 95% of the maximum average signal amplitude.

4 Environment and safety

4.1 Testing environment

Tests and measurements made on the cartridge to check the requirements of this standard shall be carried out under the following conditions:

- temperature: 68°F ± 7°F (20°C ± 4°C);
- relative humidity: 50% ± 10%;
- condition before testing: 24 hours;
- maximum wet bulb temperature: 64°F (18°C).

4.2 Operating environment

Cartridges used for data interchange shall be capable of operating under the following conditions:

- temperature: 41°F to 113°F (5°C to 45°C);
- relative humidity: 20% to 80% non-condensing;
- maximum wet bulb temperature: 79°F (26°C);
- maximum baseplate temperature (operation): 122°F (50°C).

The operating environment temperature is to be measured in the air immediately surrounding the cartridge. Baseplate temperature shall be measured on the exterior surface within a 0.5 inch (12.7 mm) radius of the belt capstan pin. Rapid temperature variations should be avoided. There shall be no deposit of moisture on or in the cartridge.

4.3 Transportation environment

During transportation, the cartridge may be exposed to conditions outside the operating environment. The recommended safe limits are:

- temperature: -40°F to 113°F (-40°C to 45°C);
- relative humidity: 20% to 80% non-condensing;
- maximum wet bulb temperature: 79°F (26°C).

If it is suspected that the cartridge has been subjected to mechanical shock simultaneously with exposure to cold, as evidenced by tape pack shift, the cartridge should be conditioned as described in 4.5.

4.4 Storage environment

During storage, the cartridge should be in an environment not to exceed the conditions of the transportation environment. Cartridges that have been exposed to temperatures above 113°F (45°C) may still be able to function usefully with a high probability of retrieving data stored on them. Under no circumstances should cartridges be exposed to temperatures in excess of 167°F (75°C) as permanent damage may occur. Whenever possible it is recommended that cartridges be stored in room environment conditions of 68°F \pm 9°F (20°C \pm 5°C), 50% \pm 20% RH.

4.5 Conditioning of the cartridge

Before use the cartridge shall be conditioned by exposure to the operating environment for a time at least equal to the period during which it has been out of the operating environment (up to a maximum of 8 hours).

The cartridge shall also be conditioned by running the tape one complete end-to-end pass in any of the following cases:

- Each time that it is inserted into a drive for test purposes in this standard;
- After prolonged operation over a limited tape length (> 50 passes over any tape length less than the full tape length);
- When the temperature change to which the cartridge has been exposed is greater than 30°F (16°C).

4.6 Safety

4.6.1 Safeness

The components of the tape and cartridge assembly shall not constitute any safety or health hazard when used in the intended manner, or through any foreseeable misuse in an information processing system.

4.6.2 Flammability

The material used in the external cartridge covers must have a flammability rating of at least 94V-2, as described in the *Underwriters Laboratory UL94 standard for safety-test for flammability of plastic materials, parts, devices and appliances*.

5 Tape mechanical and electrical properties

5.1 Tape width and tolerance

The tape width shall be 0.2470 in \pm 0.0005 (6.274 mm \pm 0.013 mm).

5.2 Tape length

The tape length between LP and EW markers shall be:

- SL cartridge: 205 ft +10 ft, -0 ft (62.5 m +3 m, -0 m);
- LL cartridge: 307.5 ft +10 ft, -0 ft (93.7 m +3 m, -0 m);

5.3 Tape thickness

The overall thickness of the tape shall be:

- SL, cartridge: 600 min (15.2 mm) maximum;
- LL cartridge: 430 min (10.9 mm) maximum.

The oxide coating thickness shall be 80 min (2.03 mm) maximum.

5.4 Tape position holes

Tape position holes for beginning of tape, load point, early warning, and end of tape will be provided as shown in figure 2. These position holes used as tape markers are symmetrically located to allow bidirectional tape control.

5.5 Leaders and splices

The cartridge shall contain no spliced-in leaders or splices.

5.6 Tape wind

The tape shall be wound on the hubs with the magnetic coating out, and in such a way that during forward read/write operations the tape is unwound in a clockwise direction viewed from the top of the cartridge as shown in figure 1.

5.7 Tensile yield force

5.7.1 Definition

The tensile yield force shall be taken as the force required to elongate the sample 3%.

5.7.2 Requirements

The tensile yield force at 3% elongation shall be:

- SL, cartridge: 1.5 lbf (6.7 N) minimum;
- LL cartridge: 1.2 lbf (5.3 N) minimum.

5.7.3 Procedure

Use static weighting, constant rate-of-grip separation tester capable of indicating the load to an accuracy of $\pm 2\%$. Clamp a specimen of tape at least 7 in (180 mm) in length, with an initial 4 in (100 mm) separation between the jaws. Elongate the specimen at a rate of 2 in (50 mm) per minute until the minimum elongation of 10% is reached. The force required to produce an elongation of 3% is the tensile yield force.

5.8 Electrical resistance

5.8.1 Definition

Electrical resistance is defined as the resistance of the oxide coating surface, measured in ohms per square.

5.8.2 Requirement

The resistance shall not exceed 5×10^9 ohms per square, but shall be greater than 1×10^4 ohms per square.

5.8.3 Procedure

After 12 hours exposure to the test environment, two layers of the sample tape shall be placed back-to-back between the strip electrodes, as shown in figures 3 and 4 such that the magnetic-oxide-coated sides are in contact with all of the electrodes. In mounting the specimen for measurements, it is important that no conducting paths exist between the electrodes except those through the specimen. To ensure that the length of tape held between each strip electrode is the same, the specimen shall be placed under $8 \text{ ozf} \pm 2 \text{ ozf}$ ($2.23 \text{ N} \pm 0.56 \text{ N}$) tension as it is being clamped.

NOTE - Neither the specimen nor the insulating surfaced shall be handled with the bare fingers. (The use of clean, lint-free gloves is recommended.)

Measurement shall be made between each pair of adjacent electrodes. This will produce a total of 5 readings per specimen. The resistance of the coating shall be determined by means of a guarded circuit, as shown in figure 4, using 500 volts, ± 10 volts, potential.

5.9 Layer-to-layer adhesion

5.9.1 Definition

Layer-to-layer adhesion refers to that property of a magnetic tape wherein one layer when held in close proximity to the adjacent layer exhibits an adhesive nature and bonds itself to an adjacent layer so that free and smooth separation of the layers is difficult.

5.9.2 Requirement

There shall be no evidence of layer-to-layer adhesion or coating delamination.

5.9.3 Procedure

A 3 ft (1m) length of tape shall be fastened at one end, magnetic side down, to a 0.5 in (12.7 mm) diameter by a 4 in (100 mm) long stainless steel cylinder with a non-oozing adhesive material. Attach the opposite end of the tape to a 0.67 lb (304 g) weight. A small strip of double-coated adhesive tape shall be affixed to the magnetic side of the tape 1 in (25.4 mm) above the weight. The tube shall then be slowly and uniformly rotated so that the tape, held in tension by the weight, winds uniformly around the tube into a compact and even roll. The double-coated tape when wound into the roll acts to secure the end to prevent unwinding with the weight in place. The tube supporting the weight is then exposed to the following temperature and humidity cycle:

Time (hr)	Temperature	Relative humidity
16 - 18	130°F (54.4°C)	85% ± 5%
4	130°F (54.4°C)	10% or less
1 - 3	70°F (21.1°C)	45% ± 5%

To evaluate the tape for adhesion the end of the roll should be opened and the sticky tab removed. The free end of the tape should then be held and the cylinder allowed to fall, thereby unwinding the tape. The unwound tape should then be checked for coating delamination with the exception of the last 2 in (50 mm) of tape nearest the cylinder.

5.10 Tape cupping

5.10.1 Definition

The departure across a tape (transverse to the direction of motion) from a flat surface is defined as cupping.

5.10.2 Requirement

The departure from a flat surface shall not exceed:

- SL cartridge: 0.015 in (0.38 mm);
- LL cartridge: 0.020 in (0.51 mm).

5.10.3 Procedure

Cut a tape length of 0.25 in (6.4 mm) and place the cut tape concave side down on a flat surface. Measurement shall be made one hour or longer after cutting.

5.11 Tape light transmission

5.11.1 Definition

Tape light transmission refers to the measure of light reflected by the mirror and transmitted through the plastic cover and tape.

5.11.2 Requirement

The tape shall have a light transmittance of less than 1% measured in a specular mode in a linear system by means of each of the following light sources when using a silicon photodiode for detection:

- A tungsten lamp having a color temperature of 2000 ± 200 K;
- A light-emitting diode having a peak output at 940 ± 60 nanometers.

5.11.3 Procedure

- 1) Test fixture: Tape light transmittance shall be measured using a tungsten lamp or a light emitting diode light source and silicon photodiode for detection as shown in the set-up of figure 12;
- 2) Test circuit: The measurement of transmittance shall be made using the circuit shown in figure 13, assuring that the photodiode is operating in the linear region (i.e. not saturated) when no tape is in place between aperture and mirror;
- 3) Light transmittance measurement: The light transmittance shall be as follows:

$$\frac{E_{\text{out}} (\text{x 100 range, tape in place})}{E_{\text{out}} (\text{x 1 range, no tape})} \%$$

The maximum light transmittance, as it applies to this standard, shall be the maximum value measured in the two zones: BOT to LP and EW to EOT. Note that the measurement includes all optical effects of the plastic cover and mirror.

6 Tape recording properties

The magnetic properties of the tape are defined by the testing requirements given in this section. When the tests are being performed, the output signal must be measured on the same relative pass for both the secondary standard reference tape cartridge and the tape cartridge under test (read-while-write or, on equipment without read-while-write capability, on the first forward read pass) on the same equipment.

6.1 Defect density

6.1.1 Definitions

6.1.1.1 defect density: The number of rejected regions observed, divided by the tested surface area is the defect density. It is expressed as defects per square inch (d/in^2) or defects per square millimeter (d/mm^2).

6.1.1.2 effective defect diameter (EDD): The EDD is computed as follows:

$$EDD = (1 - TL / 100) \times TW$$

6.1.1.3 rejected region: Any head-to-tape separation, or anomaly in the oxide surface, which produces a loss of amplitude in the playback signal below TL is a missing pulse.

A rejected region is any 1.0 in (25.4 mm) length of test track containing one or more missing pulses.

6.1.1.4 tested surface area: The tested surface area is that surface containing recorded signals exclusive of erased gaps or other non-used recording areas where errors are not detectable.

This tested surface area is the product of TW and the total length of data track areas tested. The tested surface area must lie within the test recording area shown in figure 2.

6.1.1.5 threshold level (TL): The TL is measured relative to the standard reference amplitude and is expressed as a percentage.

6.1.1.6 track width (TW): The TW is the width of recorded signal sensed by the read head.

6.1.2 Requirement

The defect density shall be less than, or equal to:

$$1.34 \times 10^{-9} \text{ EDD}^{-3.66} d/in^2 \quad (2.87 \times 10^{-7} \text{ EDD}^{-3.66} d/mm^2)$$

where: $EDD \geq 0.0032$ in (0.08 mm).

6.1.3 Procedure

The test is performed in contact over the tested surface area at 10 000 ftpi (394 ftpmm) or 14 700 ftpi (579 ftpm).

6.2 Ease of erasure

The maximum signal level remaining after subjecting a tape recorded at 3200 ftpi (126 ftpmm) with the standard measurement current of a longitudinal steady field of 1650 oersteds (131 000 A/m) shall be 3% of the standard reference amplitude.

6.3 Average signal amplitude

The average peak-to-peak signal amplitude of the tape under test shall not deviate from the standard reference amplitude by more than +25%, -10% at 10 000 ftpi (394 ftpmm) and $\pm 25\%$ at 14 700 ftpi (579 ftpmm). The averaging shall be done over a minimum of 1.0 in (25.4 mm).

The tape under test and the amplitude reference tape cartridge shall be recorded on the same equipment using the standard measurement current. The output level shall be measured on a centrally located track on the same equipment. Traceability of the average signal amplitude of the master standard reference tape is provided by the calibration factors supplied with each secondary standard reference tape.

6.4 Signal decay

6.4.1 Definition

Signal decay is a measurement of loss in signal amplitude due to cycling a tape in contact.

6.4.2 Requirements

Signal decay shall not exceed 5%, using procedure in 6.4.3.

6.4.3 Procedure

The tape under test is recorded at 10 000 ftpi (394 ftpmm) using the standard measurement current. The tape is cycled from EOT to BOT to EOT 5 times noting the average peak-to-peak signal amplitude on the last forward pass (E_5). The tape is then cycled 50 additional times, noting the amplitude on the last forward cycle as above (E_{55}).

Signal decay in percent is:

$$\frac{E_5 - E_{55}}{E_5} \times 100$$

6.5 Resolution

The resolution shall be between 80 and 120 percent of the resolution of the master standard reference tape. Traceability of the resolution of the master standard tape is provided by the calibration factors supplied with each secondary standard reference tape.

6.6 Typical field

The typical field shall be between 80 and 120 percent of the reference field of the master standard reference tape. Traceability of the reference field of the master standard tape is provided by the calibration factors supplied with each secondary standard reference tape.

7 Mechanical specifications of the tape cartridge

7.1 General description

The cartridge is a compact, coplaner design with the tape and hubs completely enclosed by the case, except for the belt capstan and head openings. The drive is via a tensioned belt, which is driven by the internal belt capstan that receives motion from an external motor (see figure 1). Tape guides are located inside the cartridge. A clear plastic top allows visual monitoring of the tape.

7.1.1 Dimensions

The dimensions of the cartridge are as shown in figure 5.

7.1.2 Mounting position

The cartridge is intended to mount in read/write machines in one position only, and cartridges shall have asymmetrical features that can be utilized to prevent engaging the cartridge improperly (see figure 5).

7.1.3 Cartridge positioning planes

The cartridge shall be referenced to the read/write machine only in the crosshatched areas shown in figure 6. The application of forces suggested in figure 6 is one method of assuring conformance of the cartridge to the positioning plane.

7.1.4 Attachment

The ends of the tape shall not be attached to the hubs.

7.1.5 Light sense

The cartridge shall contain optical elements to permit photoelectric detection of the tape position holes (see figure 7).

7.1.6 Cartridge-in-position sense

The cartridge shall have areas on the front surface and sides which, is held to the dimensions as shown in figure 8, are to be used for sensing that the cartridge is in position for writing and reading.

7.1.7 Cartridge door

The cartridge shall have a door for protection of the tape during storage and transport. Requirements for opening the door are shown in figure 9.

7.2 Physical labels

7.2.1 Location and size

The rear surface of the cartridge, opposite the exposed tape, and a portion of the top side of the cartridge may be used for labels. The rear surface area provides for readability of the label when it is in a stacked or inserted position. Position and size of the label should be within the provided depression of the label area as shown in figure 10.

7.2.2 Interchange information

Suitable labels should be used for marking contents of cartridges. The use of pencil or erasable material is not recommended.

7.3 Tape guides

The tape shall be guided by tape guides contained within the cartridge (see figure 11). The read/write machine should not contain any elements to restrict the tape path in the transverse direction.

7.4 Drop tests

The cartridge shall be able to withstand the shock incurred from falling 30 in (0.75 m) onto a concrete floor covered with asphalt tile. The cartridge shall be dropped once on one corner and once on the base. After the drops, the cartridge shall then meet all the requirements of this standard.

7.5 Speeds

The operating speed range for the cartridge is from 25 in/s (0.64 m/s) to 90 in/s (2.29 m/s).

7.6 Driving force

The tangential force, exclusive of motor rubber covered drive roller effects, required at the external driving surface of the belt capstan to maintain a constant operating speed shall be at least 1 ozf (0.28 N) but not more than 4.5 ozf (1.25 N).

The external radial load applied to the belt capstan when making this measurement shall be 14.5 ± 1.5 ozf (4.05 ± 0.42 N). The measurement shall be taken when the cartridge is driven at constant speed and a low friction contact surface (coefficient of friction < 0.1) located where the head would be when the tape cartridge is inserted in a drive.

7.7 Total inertia

The total equivalent inertial mass of all cartridge elements referred to the outer surface of the belt capstan in linear units shall not exceed 0.0008 ozf - S²/in (8.7 g).

7.8 Dynamic response

7.8.1 Definition

Dynamic response refers to the velocity response of tape motion to a step driving function applied to the belt capstan.

7.8.2 Requirement

The natural resonant frequency shall be a minimum of 60 Hz.

7.8.3 Procedure

A drive capable of producing a pronounced overshoot of the tape velocity should be used. The drive servo should be critically damped so that the overshoot observed is not that of the drive. The reciprocal of the time measured between the first two overspeed peaks is the natural resonant frequency.

7.9 Tape tension

7.9.1 Definitions

7.9.1.1 average tension: Average tension at a point along the length of the tape is the average value of the instantaneous tension measured over 3 ft (1m) of tape symmetrically located around that point.

7.9.1.2 dynamic tension: Dynamic tension at a point along the length of the tape is the maximum peak-to-peak variation of instantaneous tension over the 3 ft (1m) length of tape symmetrically located around the point.

7.9.1.3 instantaneous tension: Instantaneous tension is the tension as measured at the cross section of the tape located at the head position of the free tape path and averaged over 10 milliseconds. This value is the superposition of the average and dynamic tensions.

7.9.1.4 tape tension: Tape tension is the resultant force in the longitudinal direction of the tape on a cross section taken through the tape perpendicular to the longitudinal direction.

7.9.1.5 transverse tension variation: The transverse tension variation is that variation across the tape produced by differences in the free tape path length between the two edges of the tape.

7.9.2 Requirements

7.9.2.1 Value of instantaneous tension

- 1) In the testing environment the instantaneous tension at any point along the length of tape between LP and EW shall be between 0.50 ozf (0.14 N) and 3.5 ozf (0.97 N).
- 2) In the operating environment the instantaneous tension shall be between 0.4 ozf (0.11 N) and 3.6 ozf (1.0 N).

7.9.2.2. Value of dynamic tension

The dynamic tension at any point along the length of the tape between LP and EW shall not exceed 0.50 ozf (0.14 N) (peak to peak).

7.9.2.3 Requirement for transverse tension variation

The test rod shall not deviate from the horizontal by more than 2° at any point along the length of tape from LP to EW.

7.9.3 Procedures

7.9.3.1 Procedures for measuring instantaneous tension

- 1) Conditioning: Condition the tape before testing by winding from BOT to EOT and back to BOT;
- 2) Tape speed: The tape speed during testing shall be in accordance with 7.5;
- 3) Position of the measuring transducer: The measuring transducer shall be positioned at the point along the free tape path at which the head would be located if the cartridge were mounted in a drive. When inserted in the tape path it shall cause an increase in the path length within the limits of 7.16. It shall be perpendicular to Reference Plane B within $\pm 1^\circ$;
- 4) Characteristics of the measuring transducer. The coefficient of friction of the bearing surface shall be less than 0.1. The upper limit of its frequency response shall be at least 100 Hz. The width of the bearing surface shall be sufficient for to be in contact with the whole width of the tape.

7.9.3.2 Procedure for measuring transverse tape tension variation

- 1) Conditioning; Condition the tape before testing by winding from BOT to EOT, and back to BOT;
- 2) Position of tape for measurement: The cartridge shall be held with reference plane B vertical and the cartridge door on top and in the open position. The tape shall remain stationary at the selected point;
- 3) Characteristics of the test rod: The form and dimensions of the test rod are given in figure 14. The weight of the test rod shall be 0.5 oz (14 g). The center of gravity shall be within 0.005 in (0.13 mm) of the center of notch;
- 4) Position of the test rod: The slot of the test rod shall be centered over the point along the free tape path length at which the head would be located if the cartridge were mounted in a drive.

7.10 Drive ratio

For constant rotation of the belt capstan, the ratio of the tape velocity to the surface velocity of the belt capstan shall be $0.78 + 0.00 - 0.02$.

7.11 Belt capstan electrical resistance

7.11.1 Definition

The electrical resistance of the belt capstan refers to the measurement of the bulk resistance of the belt capstan.

7.11.2 Requirement

The electrical resistance of the belt capstan shall not exceed 1 megohm.

7.11.3 Procedure

- 1) Ensure that the contact surfaces of the belt capstan and the test fixture are clean and free from oil, grease, tarnish, or other contaminants before making the test. Refer to figure 15;
- 2) Place the belt capstan on the centering pin of the bottom contact surface, with the gate area over the relief;
- 3) Place the upper contact surface on top of the belt capstan and apply a force of 4.0 lbf (17.8 N) centrally over the capstan;
- 4) Measure the current flowing in the circuit when a potential of 500 volts \pm 5 volts is applied.

7.11.4 Test result

The current shall be 0.40 milliamperes minimum.

7.12 Instantaneous Speed Variation (ISV)

7.12.1 Definition Instantaneous Speed Variation is the variation in the instantaneous tape speed at the head, measured as a percentage of the nominal.

7.12.2 Requirements

7.12.2.1 Low Frequency ISV Within the band of zero to 1000 Hz the cartridge-induced ISV shall not exceed 4% (0-Peak). The measured ISV shall encompass discrete and combinations of frequency products within that band.

7.12.2.2 High Frequency ISV Within the band from 1000 Hz to 50 kHz, there are two separate requirements.

(1) In a streaming mode test, the continuous ISV at the resonant frequency of the cartridge (approximately 5 kHz) shall not exceed 3%.

(2) In a shuffle mode or start/stop mode, the high frequency ISV shall not exceed 5%.

7.12.3 Procedure

7.12.3.1 General Low frequency speed variations (analogous to wow) are the result of mechanical tolerances in the cartridge. Typical data-separator phase-locked loops have sufficient suppression at low frequencies that the residual time displacement error due to this component can be made negligible. High frequency speed variations (analogous to flutter) are the result of tension waves in the unsupported length of tape between the hubs. In addition to the continuous component of this high frequency ISV at the resonant frequency of the cartridge, occasionally a discrete event occurs which exceeds the normal resonant background, but is damped back to it in a period of approximately one millisecond. These discrete events can initiate with either an underspeed or an overspeed pulse which is typically 80 microseconds wide. Underspeed events are most commonly associated with a tape direction reversal or a start/stop cycle of the cartridge.

7.12.3.2 Test Circuit A standard tester is a modulation analyzer (e.g. HP8901) tuned to the frequency of the carrier. The output of an FM demodulator is filtered to select the low frequency ISV or the high frequency ISV Characteristics.

7.12.3.3 Test Method

(1) Record the tape at constant density with a record frequency not less than 200 kHz.

(2) Read the tape signals at the same tape speed used to write them, using a square wave output from the read channel connected to the input of the test circuit.

(3) In the streaming mode, measure the amplitude of the low frequency and high frequency components of the ISV.

(4) In start-stop or shuffle mode, record the occurrence of any isolated events in which the high-frequency ISV exceeds 5%, excluding events caused by missing pulse and analyzer settling at ramp-up or ramp-down.

(5) Events which occur within 1.0 ms. shall be considered a single event.

7.13 Acceleration

The cartridge shall be capable of withstanding acceleration and deceleration of the linear tape speed of 1500 in/s² (38.1 m/s²).

7.14 Dynamic tape skew

7.14.1 Definition

Dynamic tape skew is the variation of the angle that the centerline of the tape makes with reference plane B.

7.14.2 Requirements

The dynamic tape skew shall not exceed 5 minutes of arc.

7.14.3 Procedures

- 1) Write flux transitions on two test tracks over the entire recording area of the tape at speed v ;
- 2) Using the same two gaps, read the tape in the forward and reverse directions, measuring the time difference between corresponding flux transitions;
- 3) The maximum time difference t and the distance d between the centerlines of the two test tracks are used to calculate the dynamic tape skew, namely:

$$\arctan (t \times v/d) \leq 5'.$$

7.15 Head penetration

7.15.1 Definition

Head penetration is the increase in tape path length resulting from the deviation of the tape path from a straight line caused by the recording head(s) or other drive components when the cartridge is inserted in a drive.

7.15.2 Recommendation

To assure reliable tape handling and to avoid tape damage, the head penetration should be greater than 0.005 in (0.13 mm) and less than 0.040 in (1.02 mm).

7.16 Dynamic track movement variation

The dynamic track movement variation is that variation of tape track movement which is perpendicular to the direction of tape motion. The variation shall not exceed ± 0.0005 in (± 0.013 mm) from the first write pass (BOT to EOT or EOT to BOT) after the cartridge has been conditioned. The variation in the opposite direction from the first write pass shall not exceed ± 0.001 in (± 0.025 mm).

7.17 Cartridge durability

Cartridge durability shall be 1000 passes maximum at the operating environment. One cartridge pass equals BOT to EOT or EOT to BOT.

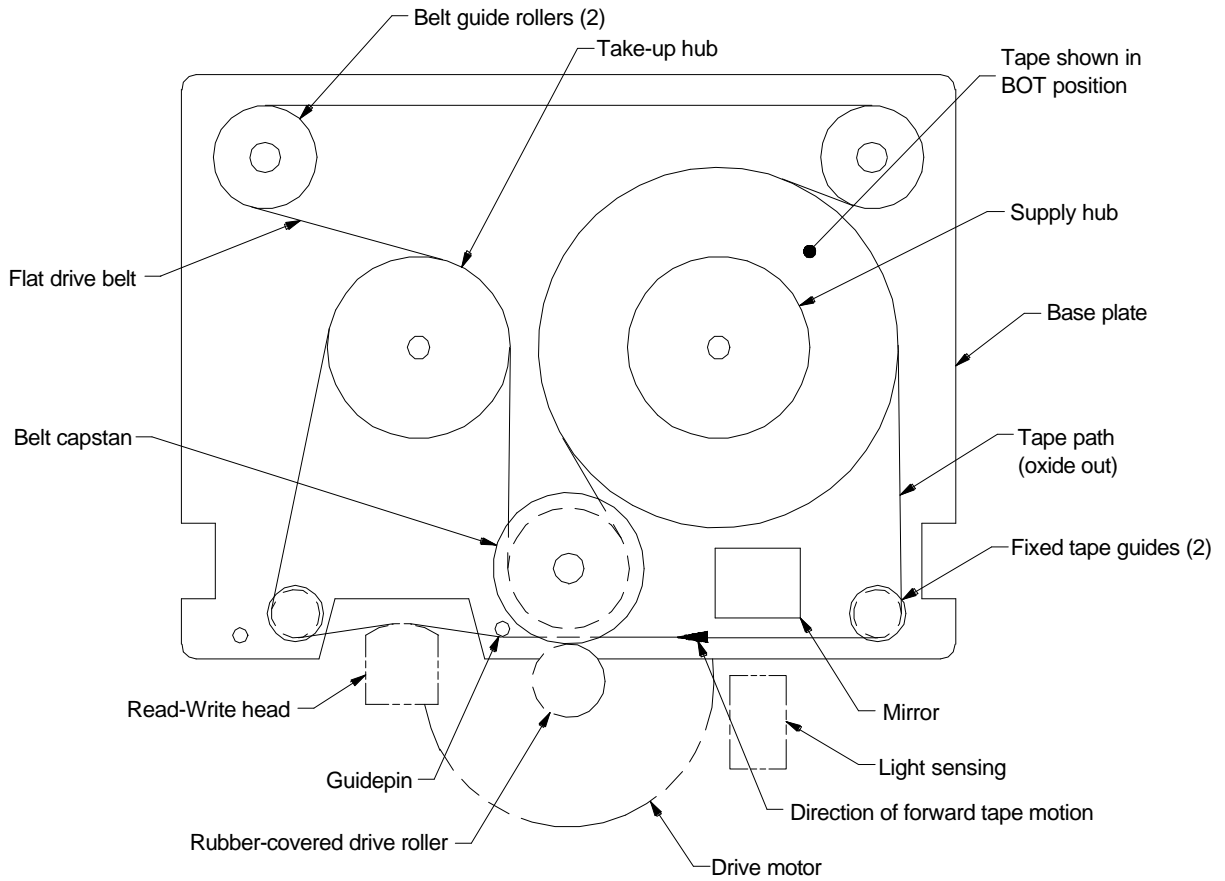
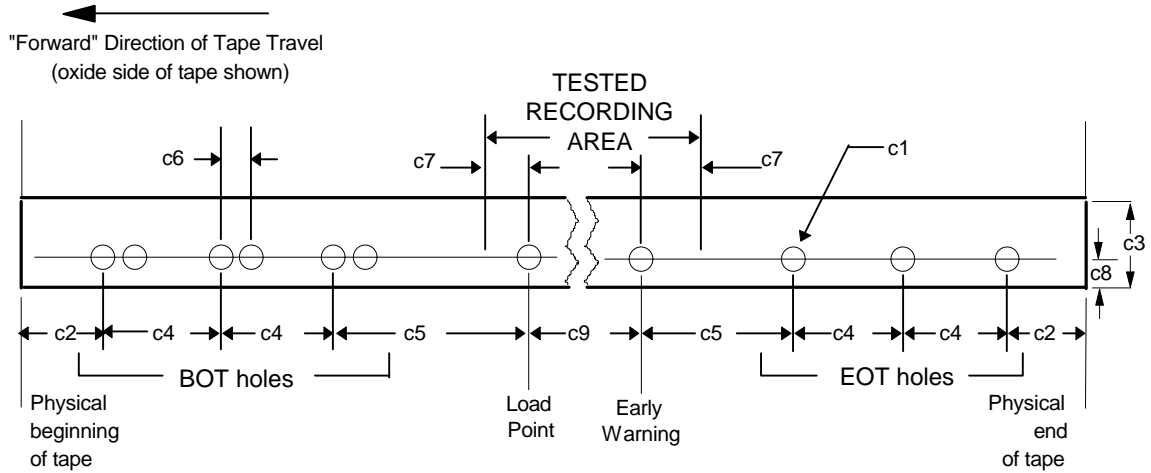
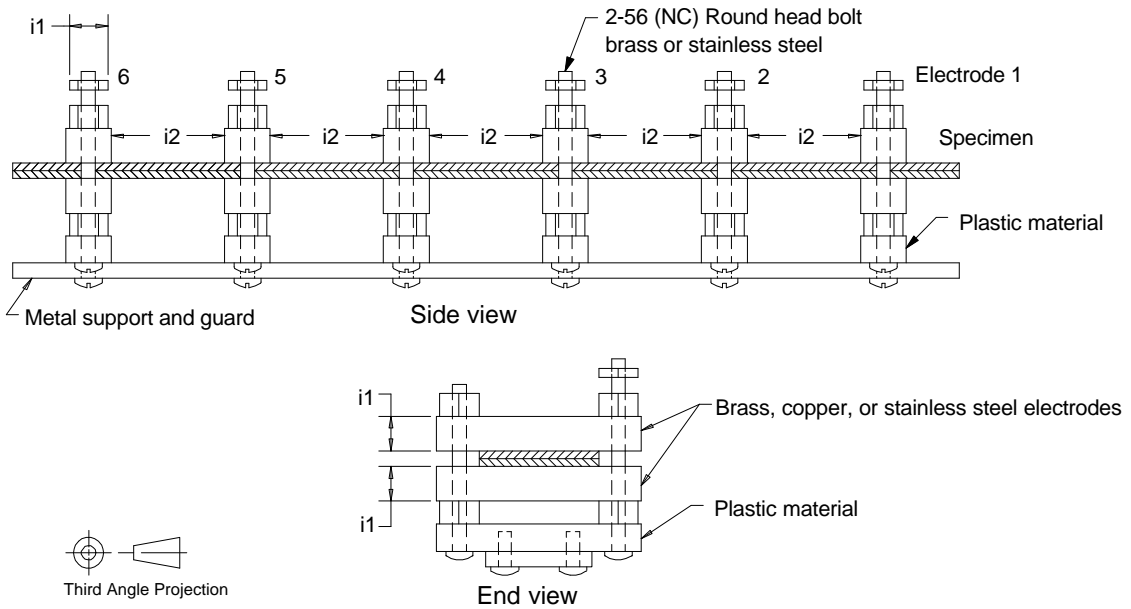

Figure 1 - Possible cartridge configurations



Dimension	Inches	Millimeters
c1 (11X)	0.046 ± 0.002	1.17 ± .05
c2 (2X)	12●●	305●●
c3	0.2470 ± 0.0005	6.274 ± 0.013
c4 (4X)	12 ± 1	305 ± 25
c5 (2X)	30 ± 1 ⁺ 36 ± 1 ⁺⁺	762 ± 25 ⁺ 914 ± 25 ⁺⁺
c6 (3X)	0.218 ± 0.010	5.54 ± 0.25
c7 (2X)	12●●	305●●
c8	0.075 ± 0.004	1.90 ± 0.10
	<u>Feet</u>	<u>Meters</u>
C9	205 +10 -0 ⁺ 307.5 +10 -0 ⁺⁺	62.5 +3.0 -0.0 ⁺ 93.7 +3.0 -0.0 ⁺⁺

- DIAMETER
- MINIMUM
- ⁺ SL CARTRIDGE
- ⁺⁺ LL CARTRIDGE



Dimension	Inches	Millimeters
i1 (Typ)	0.250	6.35
i2 (Typ)	0.500	12.70

Figure 3 - Tape resistance measurement electrodes

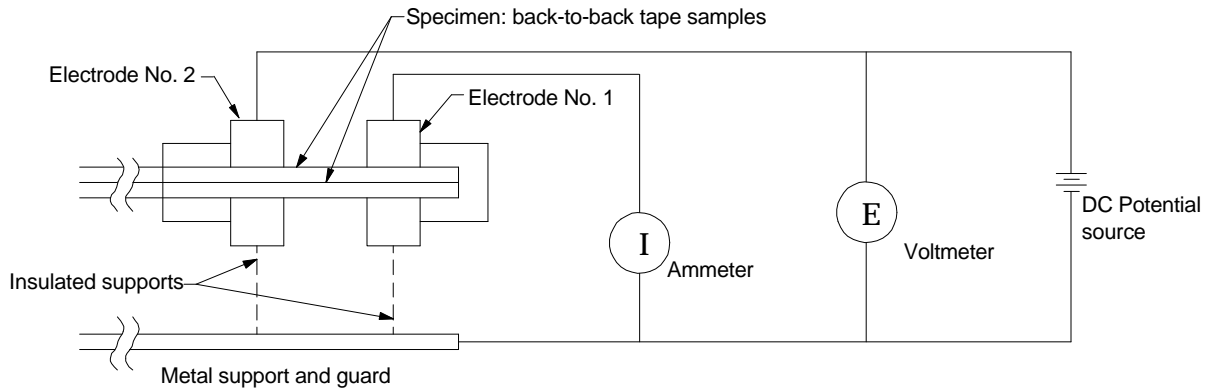
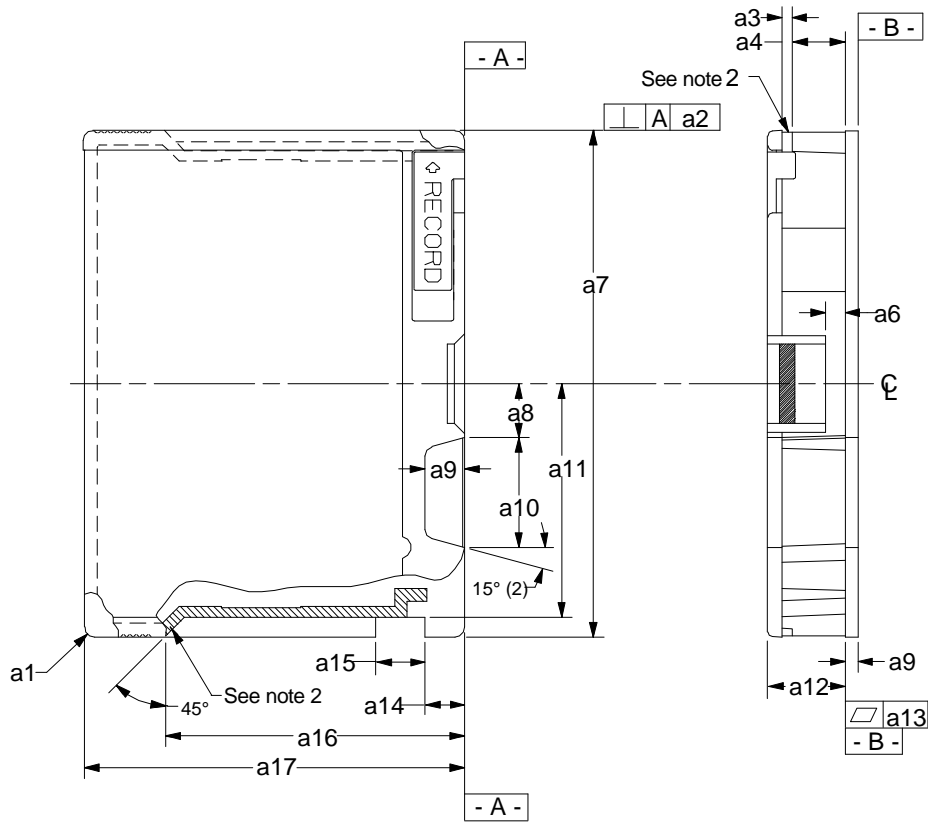

Figure 4 - Tape resistance measurement circuit



Notes:

1. All tolerances except where otherwise noted are ± 0.005 in (± 0.13 mm), $< 0.5^\circ$.

2. Features required to prevent inserting cartridge improperly.

3. Cover (top edge) may extend beyond base 0.010 in (0.25mm) maximum, also all sides except at notches.

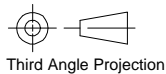

Dimensions	Inches	Millimeters
a1 (6X) (Radius)	0.062	1.57
a2	0.005	0.13
a3	0.066	1.68
a4	0.334	8.48
a5 (Base mat'l thk)	0.080 +0.003 -0.005	2.03 +0.08 -0.13
a6	0.125 \pm 0.010	3.18 \pm 0.25
a7	3.188	80.98
a8	0.344	8.74
a9	0.250	6.35
a10	0.687	17.45
a11	1.454	36.93
a12 (Maximum)	0.500	12.70
a13	0.005	0.13
a14	0.250	6.35
a15	0.312	7.92
a16	1.906 \pm .010	48.41 \pm 0.25
a17	2.406	61.11

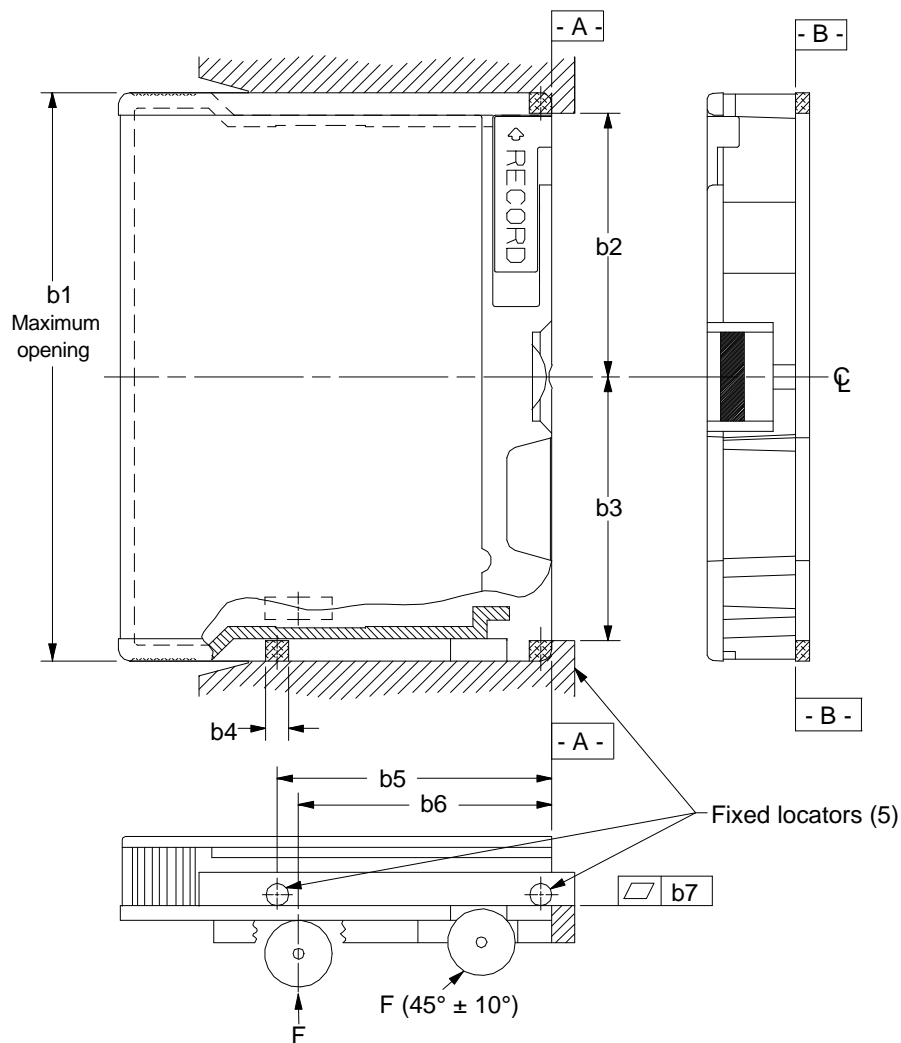

Notes:

1. All tolerances except where otherwise noted are ± 0.005 in (± 0.13 mm).
2. Fixed locators (2x) along $-A-$ defined as datum $-A-$.
3. b4 (3x) indicates cartridge plane locations defined as datum $-B-$.

Dimensions	Inches	Millimeters
b1	3.210	81.53
b2	1.480	37.59
b3	1.480	37.59
b4 (3X)	0.200	5.08
b5	1.525	38.74
b6	1.344	34.13
b7	0.005	0.13

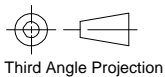

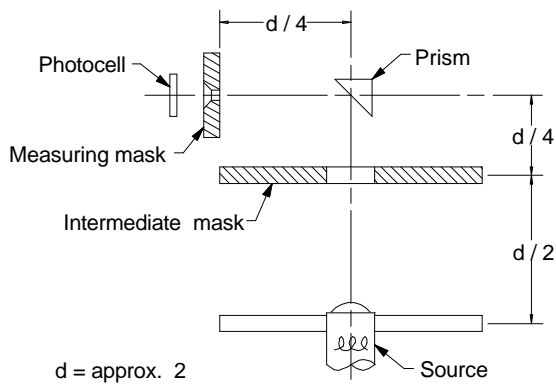

Calibration configuration

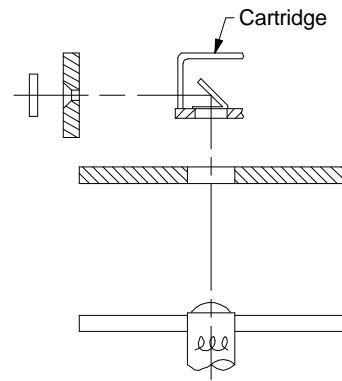

Test configuration

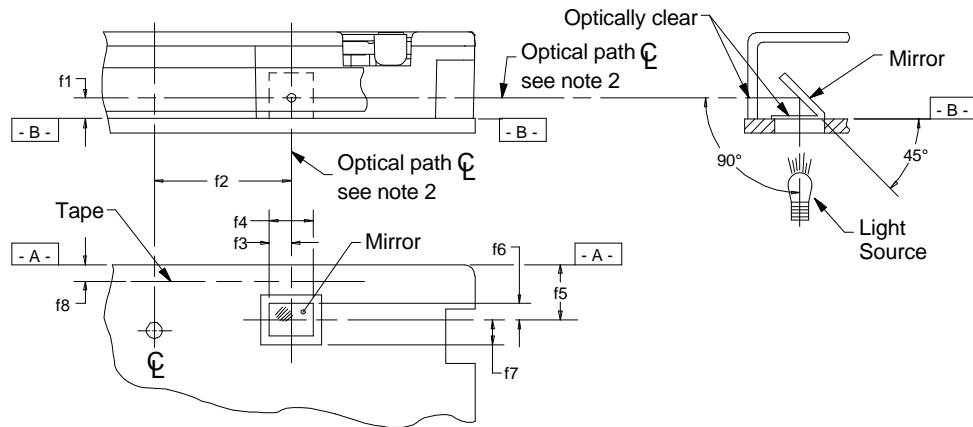

Notes:

1. All tolerances except where otherwise noted are ± 0.005 in (± 0.13 mm).
2. Optical paths perpendicular to \bar{B} plane reflected by the mirror at 90° through the tape position holes at f_1 , f_2 shall not deviate from 90° by more than $\pm 3^\circ$ in all directions.
- 3 Total optical transmission of both cover windows (including effects of reflection off mirror surface) to each of the following light sources shall be 50% minimum when sensed by a silicon photo cell:
 - a) 2000 ± 200 K tungsten lamp
 - b) 940 ± 50 nanometer LED.

Dimensions	Inches	Millimeters
f1	0.120	3.05
f2	0.781	19.84
f3	0.164 ± 0.011	4.17 ± 0.28
f4	0.328 ± 0.021	8.33 ± 0.53
f5	0.332	8.43
f6	0.085 ± 0.010	2.16 ± 0.25
f7	0.170 ± 0.020	4.32 ± 0.51
f8	0.095 ± 0.007	2.41 ± 0.18

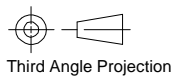

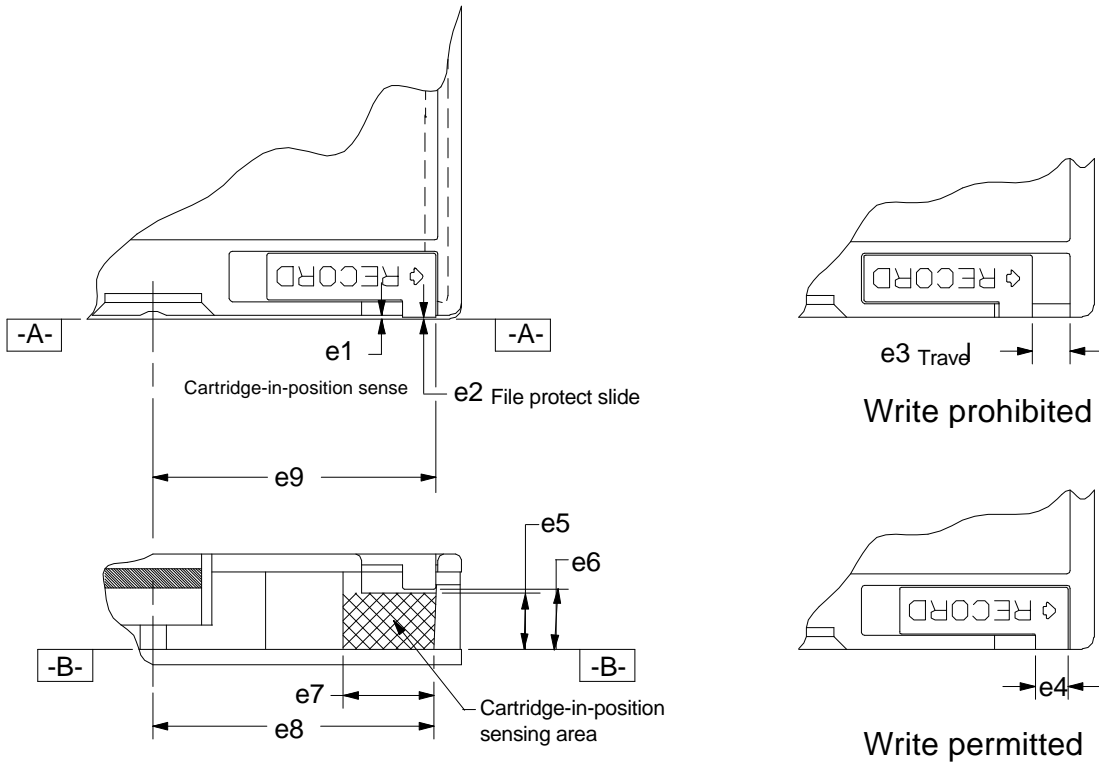

Note:
 All tolerances except
 where otherwise noted are
 ± 0.005 in (± 0.13 mm).

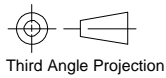

Dimensions	Inches	Millimeters
e1	0.000 ± 0.010	0.00 ± 0.25
e2	0.000 ± 0.010	0.00 ± 0.25
e3	0.150 ± 0.010	3.81 ± 0.25
e4	0.190	4.83
e5	0.300	7.62
e6	$0.305 + 0.010 - 0.000$	$7.75 + 0.25 - 0.00$
e7	0.473 ± 0.010	12.01 ± 0.25
e8	1.450 ± 0.010	36.83 ± 0.25
e9	1.450 ± 0.020	36.83 ± 0.51

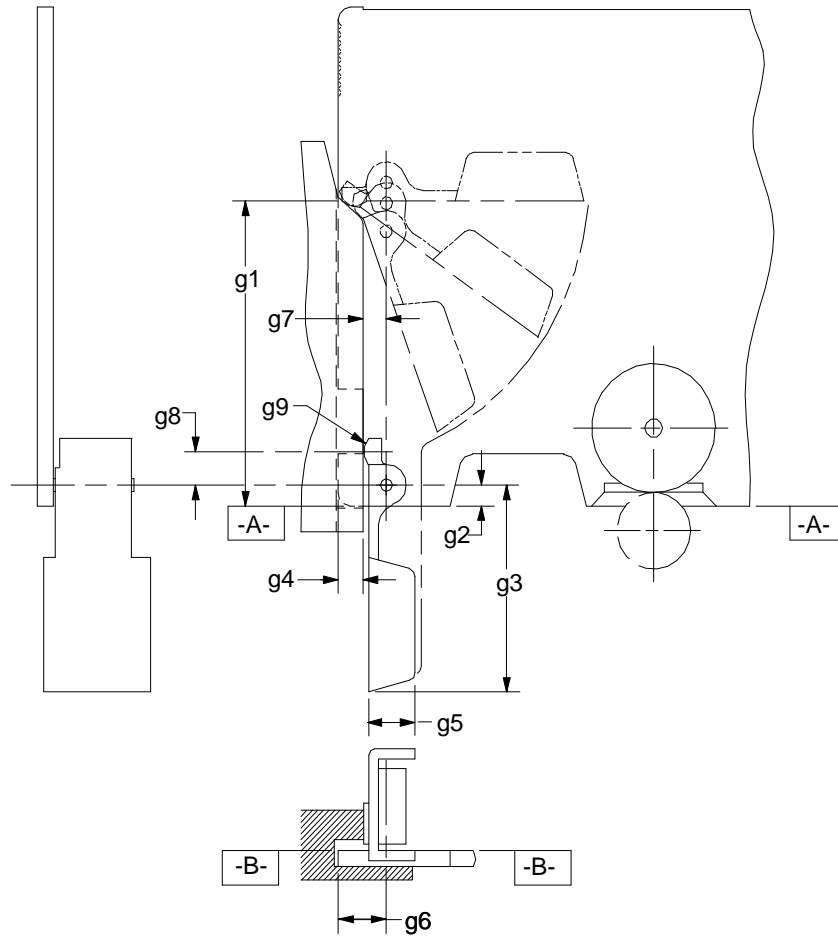

Note:
 All tolerances except where
 otherwise noted are ± 0.005 inch
 (± 0.13 mm).

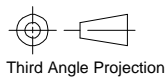

Dimension	Inches	Millimeters
g 1 (Minimum)	1.250	31.75
g 2	0.100	2.54
g 3	$1.000 + 0.005 - 0.010$ *	$25.40 + 0.13 - 0.25$ *
g 4	0.125	3.18
g 5	$0.250 + 0.005 - 0.010$ *	$6.35 + 0.13 - 0.25$ *
g 6	0.241	6.12
g 7	0.115 *	2.92 *
g 8	0.161 *	4.09 *
g 9 (Radius)	0.093 *	2.36 *

* Door dimensions

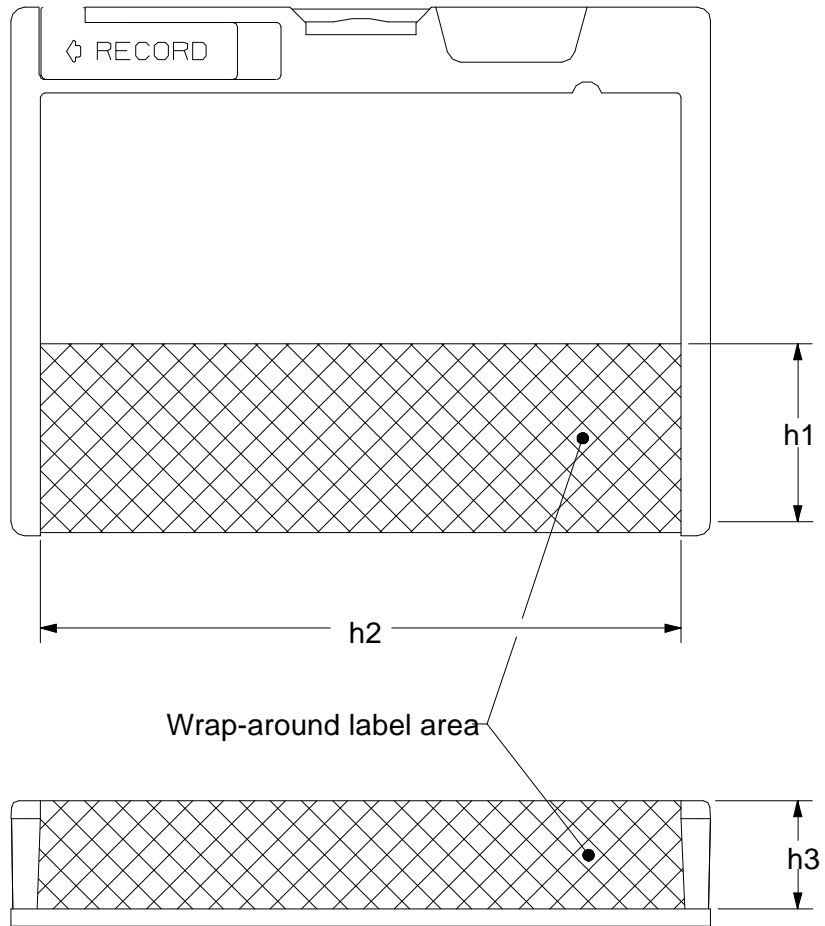

Note:
 All tolerances except
 where otherwise noted are
 ± 0.005 in (± 0.13 mm).

Dimension	Inches	Millimeters
h1	0.625	15.88
h2 (Minimum)	2.875	73.02
h3	0.437	11.10

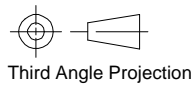

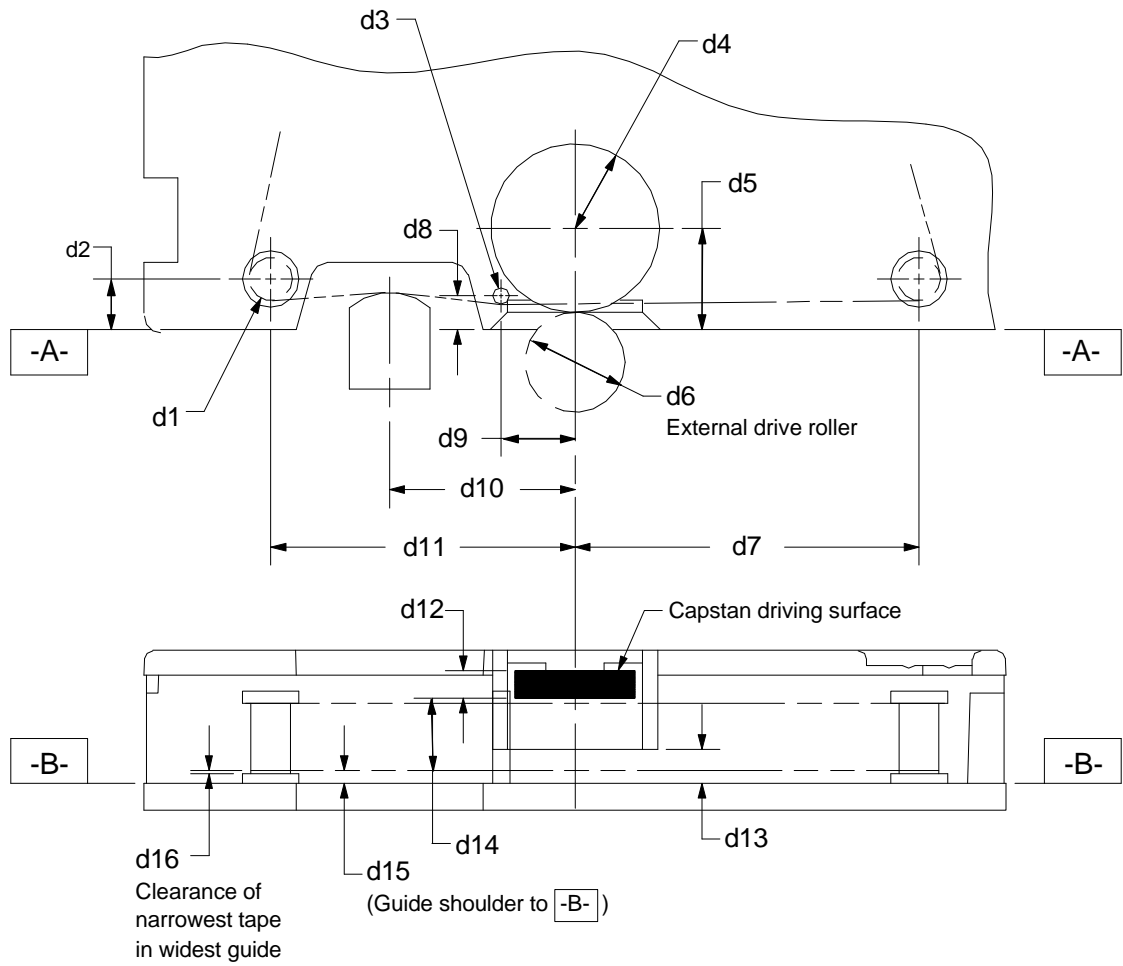

Note:
 All tolerances except
 where otherwise noted are
 ± 0.005 in (± 0.13 mm).

Dimension	Inches	Millimeters
d1 (2X) (Diameter)	0.187	4.75
d2	0.188	4.78
d3 (Diameter)	0.062	1.57
d4 (Radius)	0.312	7.92
d5	0.375	9.52
d6 (Max Diameter)	0.875	22.22
d7	1.272	32.31
d8	0.125	3.18
d9	0.273	6.93
d10	0.700	17.78
d11	1.125	28.58
d12	0.100	2.54
d13	0.125 ± 0.010	3.18 ± 0.25
d14	0.315 ± 0.010	8.00 ± 0.25
d15	0.045 ± 0.0015	1.14 ± 0.04
d16 (Maximum)	0.0018	0.046

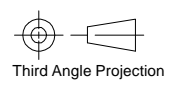

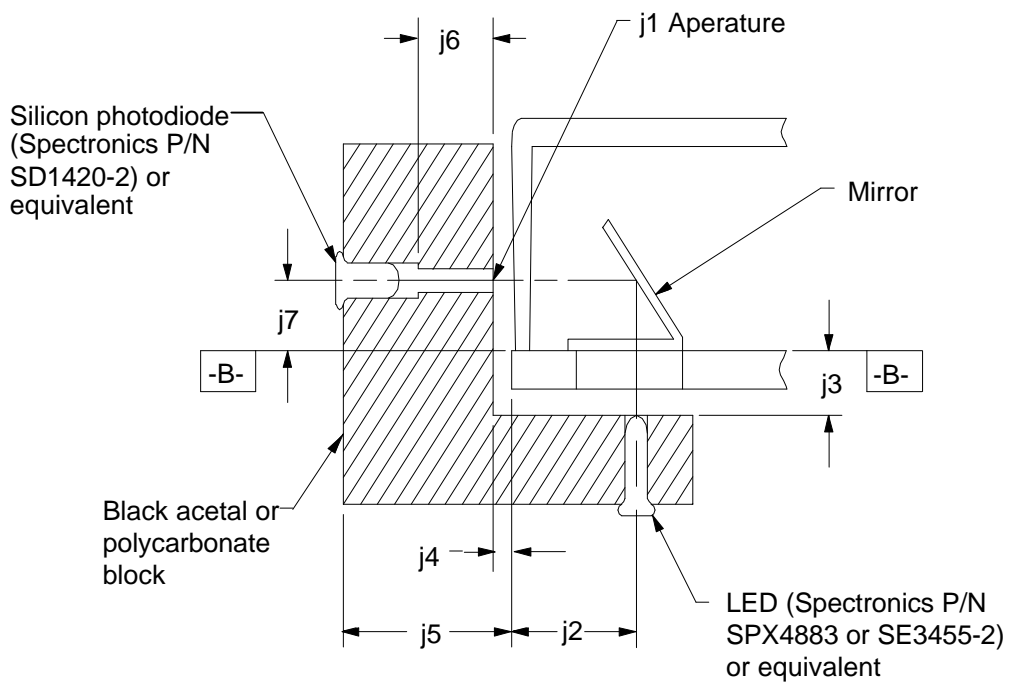

Note: - All tolerances except where otherwise noted are ± 0.005 in (± 0.13 mm).

Dimensions	Inches	Millimeters
j1 (Diameter)	0.080 ± 0.002	2.03 ± 0.05
j2	0.332	8.43
j3	0.110	2.79
j4	0.050	1.27
j5	0.450	11.43
j6	0.200	5.08
j7	0.120	3.05

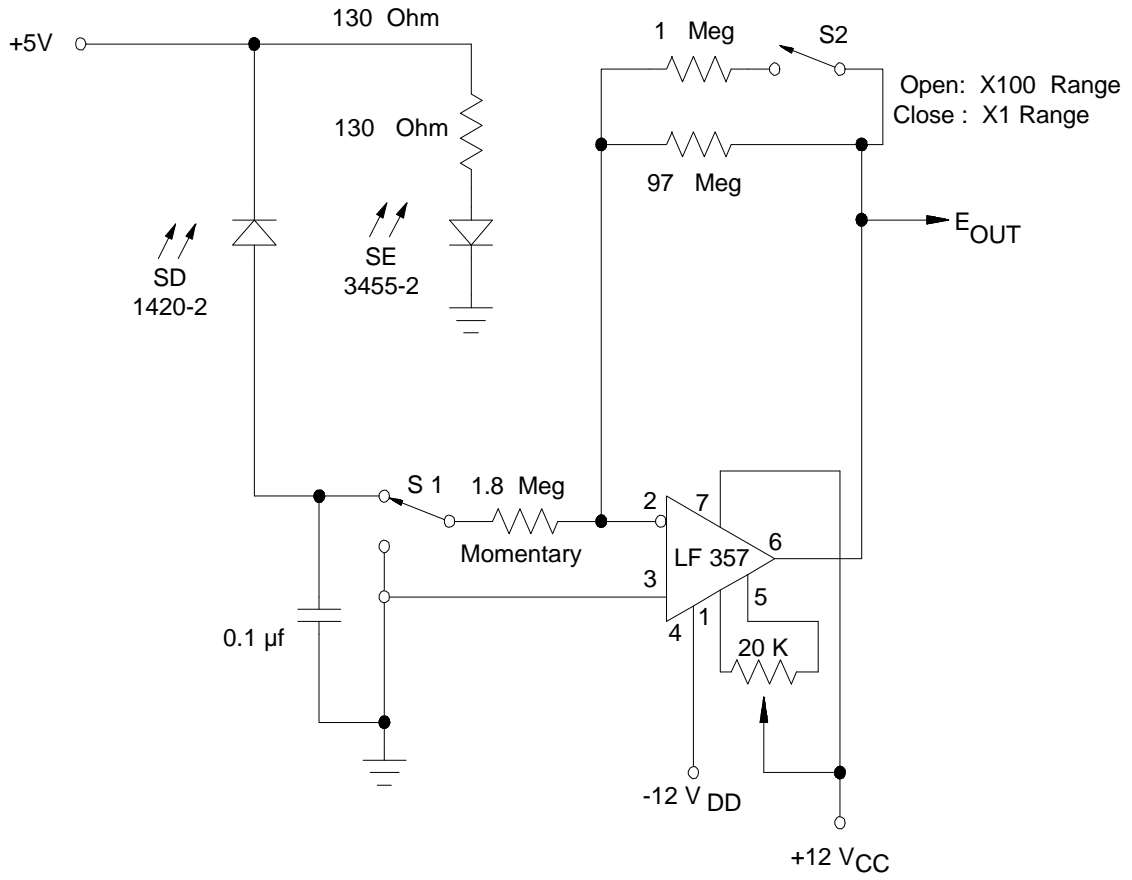
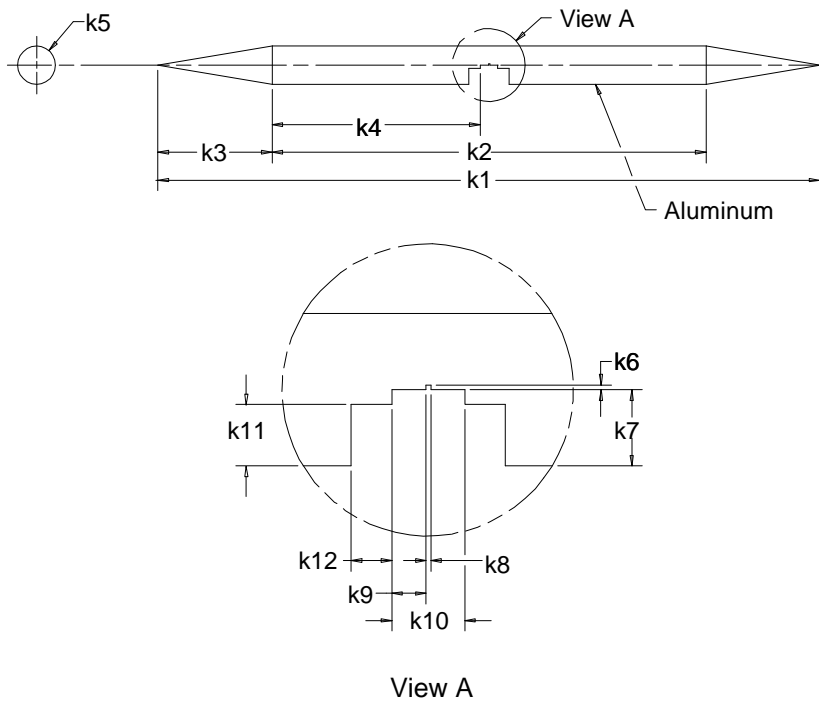

Figure 13 - Tape light transmission test



Notes:

1. All tolerances except where otherwise noted are ± 0.005 in (± 0.13 mm).

2. When notch is placed on a level edge 0.009 ± 0.001 in (0.229 ± 0.025 mm) wide, bar shall balance with no noticable lean.

Dimension	Inches	Millimeters
k1	5.450	138.43
k2	3.574	90.78
k3	0.938	23.83
k4	1.662	42.21
k5 (diameter)	0.312	7.92
k6	0.010	0.25
k7	0.156	3.96
k8	0.011 ± 0.001	0.279 ± 0.025
k9	0.119 ± 0.001	3.023 ± 0.025
k10	0.249 ± 0.001	6.325 ± 0.025
k11	0.125	3.18
k12 (2X)	0.250	6.35

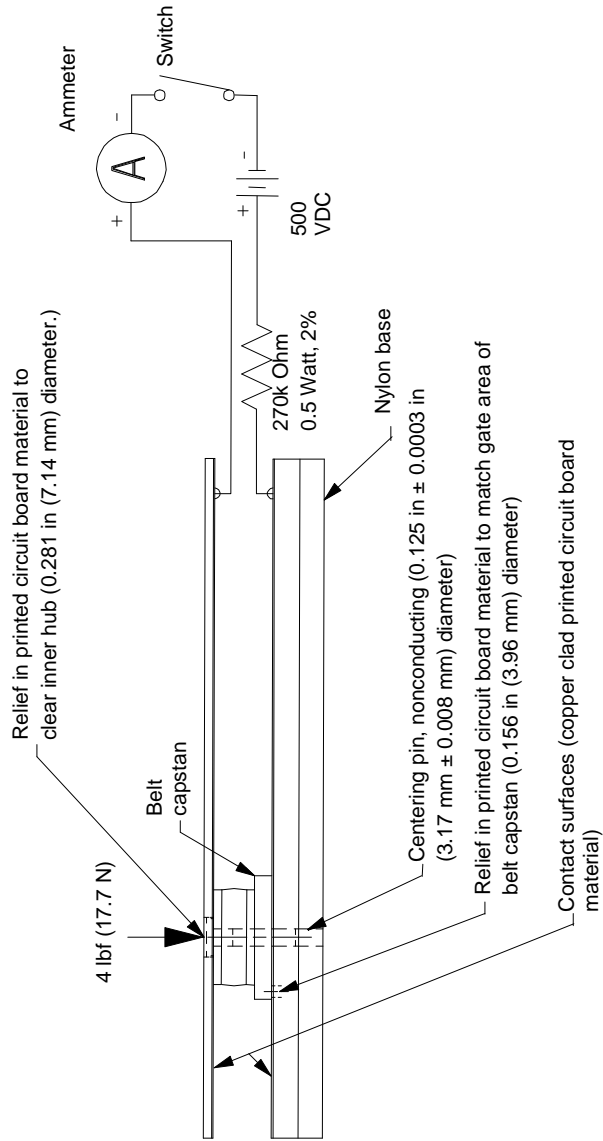

Note:
All tolerances except where noted are ± 0.005 in (± 0.13 mm).

Figure 15 - Belt capstan electrical resistance test fixture