



DEVELOPMENT STANDARD

QIC-525-DC
Revision H
10 Mar 94

SERIAL RECORDED MAGNETIC TAPE DATA CARTRIDGE FOR INFORMATION INTERCHANGE

Streaming Mode
Read-While-Write
0.250 in. (6.35 mm) Tape
26 Tracks
Transition Density: 20,000 ftpi (787 ftpmm)
Data Density: 16,000 bpi (630 bpmm)
GCR 0,2 4,5 Encoding
Reed-Solomon ECC

Uncompressed Formatted Capacity:
525 MBytes with DC6525 or Equivalent Cartridge
320 MBytes with DC6320 or Equivalent Cartridge

**Quarter-Inch
Cartridge
Drive Standards, Inc.**

311 East Carrillo Street
Santa Barbara, California 93101
Telephone (805) 963-3853
Fax (805) 962-1541
www.qic.org

(See important notices on the following page)

Important Notices

This document is a development standard adopted by Quarter-Inch Cartridge Drive Standards, Inc. (QIC). This document may be revised several times during the development cycle. It is intended solely as a guide for companies interested in developing products which can be compatible with other products developed using this document. QIC makes no representation or warranty regarding this document, and any company using this document shall do so at its sole risk, including specifically the risks that a product developed will not be compatible with any other product or that any particular performance will not be achieved. QIC shall not be liable for any exemplary, incidental, proximate or consequential damages or expenses arising from the use of this document. This development standard defines only one approach to the product. Other approaches may be available in the industry.

This development standard is an authorized and approved publication of QIC. The underlying information and materials contained herein are the exclusive property of QIC but may be referred to and utilized by the general public for any legitimate purpose, particularly in the design and development of quarter-inch tape cartridge drive subsystems. This development standard may be copied in whole or in part *provided* that no revisions, alterations or changes of any kind are made to the materials contained herein. Only QIC has the right and authority to revise or change the material contained in this development standard, and any revisions by any party other than QIC are totally unauthorized and specifically prohibited.

Compliance with this development standard may require use of one or more features covered by proprietary rights (such as features which are the subject of a patent, patent application, copyright, mask work right or trade secret right). By publication of this development standard, no position is taken by QIC with respect to the validity or infringement of any patent or other proprietary right, whether owned by a Member or Associate of QIC, or otherwise. QIC hereby expressly disclaims any liability for infringement of intellectual property rights of others by virtue of the use of this development standard. QIC has not and does not investigate any notices or allegations of infringement prompted by publication of any QIC development standard, nor does QIC undertake a duty to advise users or potential users of QIC development standards of such notices or allegations. QIC hereby expressly advises all users or potential users of this development standard to investigate and analyze any potential infringement situation, seek the advice of intellectual property counsel, and, if indicated, obtain a license under any applicable intellectual property right or take the necessary steps to avoid infringement of any intellectual property right. QIC expressly disclaims any intent to promote infringement of any intellectual property right by virtue of the evolution, adoption, or publication of any QIC development standard.

Table of Contents:

Table of Contents:	2
Overview of Revision Changes:	5
1.1 Scope	6
1.2 Introduction	7
2 DEFINITIONS	8
3 REFERENCE EDGE	12
4 TRACK GEOMETRY	12
4.1 Track Positions	12
4.2 Track Width	12
4.3 Reference Bursts	12
4.4 Quick File Access	12
5 RECORDING	16
5.1 Method of Recording	16
5.2 Transition Densities	16
5.3 Average Transition Cell Length Variations	16
5.3.1 Average Transition Cell Length	16
5.3.2 Long Term Average Transition Cell Length	16
5.3.3 Short Term Average Transition Cell Length	16
5.3.4 Rate of Change of Transition Cell Length	16
5.3.5 Instantaneous Flux Transition Spacing	17
5.4 Signal Amplitude of a Recorded Cartridge for Data Interchange	18
5.4.1 Average Signal Amplitude at nominal maximum Density	18
5.4.2 Maximum Signal Amplitude	18
5.4.3 Minimum Signal Amplitude	19
5.5 Recorded Azimuth	19
5.6 Erasure	19
6 USE OF TRACKS	20
6.1 Data Tracks	20
6.2 Track Numbering	20
6.3 Forward Reference Bursts	20
6.4 Reverse Reference Burst	20
6.5 Minimum/Maximum Distances, Even Tracks	21
6.6 Minimum/Maximum Distances, Odd Tracks	21
6.7 Summary of Requirements	22
7 BYTE AND CODE REQUIREMENTS	24
7.1 Byte Length	24
7.2 Code	24
8 TRANSFORMING OF CODED CHARACTERS PRIOR TO RECORDING ON THE TAPE	25
9 TRACK FORMAT	26
9.1 FRAMES	26
9.1.1 General Information	26
9.1.2 Frame Layout	26
9.2 Block types	27
9.2.1 Data Block	27
9.2.2 QIC-525 Identifier Block	27
9.2.2.1 Identifier Block 0	27
9.2.2.2 Identifier Block 1	28
9.2.2.3 Identifier Block 2	29
9.2.2.4 Identifier Blocks 3 and 4	31
9.2.2.5 Identifier Block 5	32

9.2.2.6 Identifier Blocks 6, 7 and 8	32
9.2.2.7 Reading Out Identifier Block Information.....	32
9.2.3 File Mark Block.....	32
9.2.4 Filler Block.....	33
9.2.5 ECC Block.....	33
9.2.6 Setmark Block	33
9.2.7 Cancel Mark Block (Optional)	33
9.3 BLOCK FORMAT	34
9.3.1 General Layout	34
9.3.2 Preamble	34
9.3.3 Block Marker	35
9.3.4 Data Field	35
9.3.5 Control Field.....	36
9.3.6 CRC FIELD.....	38
9.3.7 Postamble.....	39
9.4 Block Rewrites.....	39
9.5 Fixed and variable blocks	40
9.5.1 Fixed Host Blocks, 1024 Data Bytes	41
9.5.2 Fixed Host Blocks, QIC-02 Compatible.....	41
9.5.3 Variable Host Blocks, < 1024 Data Bytes	41
9.5.4 Variable Host Blocks, > 1024 Data Bytes	41
9.6 Append Operation.....	44
9.7 DATA COMPRESSION	45
9.9.1 General Rules	45
9.9.2 Compression Block Group	45
9.9.3 Data Compression with Fixed or Same Sized Blocks	45
9.9.4 Data Compression with Variable Blocks.....	45
9.9.5 Compression Header.....	45
9.9.6 Configuration of drive for datacompression.....	48
10 ERROR CORRECTION	49
10.1 Error Correction Matrix Format	49
10.2 Field Representation	49
10.3 Code Generator Polynomial	50
10.4 Example Codewords.....	50
APPENDIX A.....	52
APPENDIX B.....	53

FIGURES :

4.1 Track Location.....	14
5.1 Rate of Change Test Pattern	17
5.2 Test Pattern Instantaneous Flux Transitions Spacing	18
6.1 Requirements for Use of Tracks	23
9.1 General Track Layout.....	26
9.2 General Frame Layout	26
9.3 Layout of first 8 Bytes ID Frame.....	28
9.4 Layout Block 0, ID Frame.....	28
9.5 Layout of Identifier Block	30
9.6. Layout of Identifier Block 5	32
9.7 Layout of a block.....	34
9.8 Layout of Control Field.	36
9.9 Layout of Control Byte 3.....	36
9.10 Layout of Control Bytes 0-2.....	38
9.11 Rewrite Operation.....	40
9.12 Layout of Data Field, Physical Variable Data Blocks	41

9.13 Variable Host Block, 4096 Bytes.....	42
9.14 Variable Host Block, 2051 Data Bytes.....	42
9.15 Variable Host Block, 1673 Data Bytes.....	43
9.16 Postamble/Preamble overlap during append operations.....	44
10.1 Bit Numbering Convention.....	49
10.2 ECC Frame Format.....	50

TABLES:

4.1 Track Positions.....	15
6.1 Requirements for Use of Tracks.....	22
8.1 Encoding Table.....	25
9.1 Inquiry Data Format.....	29
9.3 Block Descriptor List.....	31
9.4 Page Descriptor List.....	31
9.5 Encoding of Block Type Control Bits.....	37
10.1 Example of Codewords.....	51

Overview of Revision Changes:

Revision A:

This is the first edition of this document. It is based upon QIC 90-47 Rev A3.

Revision B:

Some pages has been changed.

Revision C:

Some pages has been changed.

Revision D:

Some pages has been changed.

Revision E:

Some pages has been changed.

Revision F:

Some pages has been changed.

Revision G:

Some pages has been changed.

Revision H:

Redefinition of Compression Block Group according to QIC 94-16.

1.1 Scope

This Standard provides a format and recording standard for a streaming 0.250 inch (6.3 mm) wide, 26 track, magnetic tape in a cartridge to be used for information interchange between information processing systems, communication systems, and associated equipment utilising a standard code for information interchange, as agreed upon by the interchange parties. The Standard provides a typical capacity of 525 MByte of formatted data on a single DC6525 cartridge (or equivalent) using read-while-write verification and error correction codes. Using the DC6320 cartridge (or equivalent) the capacity is 320 Mbyte of formatted data.

This standard refers solely to recording on the 0.250 inch (6.30 mm) magnetic tape cartridge. It complements the proposed American National Standard Unrecorded Magnetic Tape Cartridge for Information Interchange, 0.250 inch (6.30 mm), 12 500 fpi (492 ftpmm), X3B5/87-165 (or the latest revision), where the following sections are dealt with in detail : general requirements, definition, tape and cartridge, physical and magnetic requirements, speed requirements, and write enable feature. Compliance with the unrecorded standard is a requirement for information interchange. To meet the performance requirements in this standard may require media certification beyond media certified to this ANSI standard.

CAUTION NOTICE: Compliance with this development standard may require use of one or more proprietary rights (such as features which are the subject of a patent, patent application, copyright, mark work right or trade secret right). By publication of this development standard, no position is taken by QIC with respect to the validity of any patent or other claim of proprietary rights in connection therewith. Persons proposing a feature in this development standard which is the subject of a claim of patent rights or other proprietary rights may have notified QIC of such claim. No representation or warranty is made or implied that the filed notice will disclose all patented and proprietary rights that could be the subject of infringement by use of this development standard.

1.2 Introduction

1.2.1.

This standard defines the requirements of supporting test methods necessary to ensure interchange at acceptable performance levels. It is distinct from a specification in that it delineates a minimum of restrictions consistent with compatibility in interchange transactions. The standard uses a Reed Solomon error correction code to achieve a corrected bit error rate of at least 10^{-14} given a raw error rate of 10^{-8} .

1.2.2

The performance levels contained in this standard represent the minimum acceptable levels of performance for interchange purpose. They therefore represent the performance levels which the interchanged items should meet or surpass during their useful life and thus define end-of-life criteria for interchange purposes.

The performance levels in this standard are not intended to be employed or substituted for purchase specification.

1.2.3

Wherever feasible, quantitative performance levels which must be met or exceeded in order to comply with this standard are given. In all cases, including those in which quantitative limits for requirements falling within the scope of this standard are not stated but are left to agreement between interchange parties, standard test methods and measurement procedures shall be used to determine such quantities.

1.2.4

U.S. engineering units are the original dimensions in this standard. Conversions of tolerated dimensions from customary U.S. engineering units(similar to British Imperial Units) to SI units have been done in this standard according to ANSI/IEEE STD 268-1982 and ISO 370-1975 Method A. Method A should be used for economy unless a requirement for absolute assurance of a fit justifies use of Method B. In the national standards of ISO member nations, additional rounding may be done to produce "preferred" values. These values should lie within or close to the original tolerance ranges.

1.2.5

Except as indicated in 1.2.3 above, interchange parties complying with the applicable standards should be able to achieve compatibility without need for additional exchange of technical information.

2 DEFINITIONS

For the purpose of this standard, the following definitions apply:

Bad Block:	A block determined to be bad during the Read-While-Write operation, or later during a read operation.
Bit:	A single digit in the binary digit system.
Bit Cell:	The physical length of a recorded encoded bit along the track.
Block:	A group of 1024 consecutive data bytes plus additional control bytes recorded as a unit.
Block Marker:	A group of encoded bits following the preamble and marking the start of each block.
BOT (Beginning of Tape) Marker:	<p>The BOT Marker is a set of two holes punched in the tape. There are three sets of holes provided, the innermost of which is used for identifying the storage position for the cartridge. The additional sets of holes are used ensure reliability of detection.</p> <p>Note: In the storage position, all of the permissible recording area of the tape is wound on the supply hub and is protected by at least one layer of tape not used for recording data. Cartridges to be interchanged shall be rewound to the storage position prior to interchange.</p>
Byte:	A group of 8 data bits (10 encoded bits) operated upon as a unit.
Cancel Mark:	A block which may (optionally) be recorded after two logically consecutive File Marks at End of File. The Cancel Mark acts as a "negative" File Mark so that the second File Mark is not reported to the host. Cancel Marks are never reported to host.
Control Field:	A group of 4 bytes recorded after the data area in each block, containing information about block address, track address and block type.
Compression Block Group:	A group of compressed fixed blocks recorded as one variable block on the tape. The Compression Block Group also contains a Compression Header recorded at the beginning of the Compression Block Group.
Compression Header:	A group of 10 bytes recorded as uncompressed data at the beginning of a Compression Block Group. The Header contains specific information related to the compressed data block recorded on the tape.

CRC (Cyclic Redundancy Check):	The CRC is a group of 4 bytes recorded at the end of each block of data for the purpose of error detection.
Data Block:	A block containing user valid data in its data field.
Data Density:	The nominal distribution of recorded data information per unit length of track, usually expressed in bits per inch (bpi) or bits per millimeter (bpmm).
ECC (Error Correction Code):	Special drive generated information which may be used to correct bad blocks.
ECC Block:	A block containing drive generated ECC data in its data field and part of control field.
Encoding:	A method where by a group of data bits is translated into a group of recording bits. In this standard, 4 data bits are translated into 5 encoded bits to be recorded.
EOT (End of Tape) Marker:	The EOT Marker is a single hole punched in the tape to indicate that the usable recording area of the tape has been exceeded, and that the physical end of the tape is approaching. There are three EOT holes to ensure reliable detection.
EW (Early Warning) Marker:	The EW Marker is a single hole punched in the tape to indicate the approaching end of the usable recording area in the forward direction.
File Mark Block:	A block designated as a File Mark.
Filler Block:	A block containing no valid information in its data field. The purpose of this block is to complete a frame in the case that the host cannot fill the whole frame with valid data information.
Flux Transition:	A point on the magnetic tape which exhibits maximum free space flux density normal to the tape surface.
Flux Transition Spacing:	A distance on the magnetic tape between flux transitions.
Frame:	A group of 16 blocks forming a complete logical unit.
GBytes (GB):	This standard defines 1 GB to be equal to 10^9 bytes (= 1000 MBytes).

GCR (Group Coded Recording):	A method whereby a group of data bits (in this standard: 4) is translated into a group of recording bits (in this standard: 5) prior to the recording.
Identifier Block:	A unique block identifying the type of format being recorded.
LP (Load Point) Marker:	The LP Marker is a single hole punched in the tape to indicate the approaching start of the usable recording area in the forward direction.
Magnetic Tape Cartridge:	A cartridge containing 0.250 inch (6.30 mm) wide magnetic tape wound on two coplanar hubs with an internal drive belt to transport the tape between the hubs.
MBytes (MB):	This standard defines 1 MB to be equal to 10^6 bytes.
Physical Recording Density:	See transition density.
Postamble:	A special sequence of bits recorded at the end of each block.
Preamble:	A special sequence of bits recorded at the beginning of each block.
Read-While-Write:	A method where data being recorded is read and verified on the same pass as they are written. Sometimes called Read-After-Write.
Recorded Azimuth:	The angular deviation, in minutes of arc, of the recorded mean flux transition line from the line normal to the cartridge reference plane.
Reference Tape Cartridge:	A tape cartridge selected for a given property for calibrating purposes.
Secondary Reference Tape Cartridge:	A tape cartridge intended for routine calibration purposes, the performance of which is known and stated in relation to that of the Reference Tape Cartridge.
Signal Amplitude Reference Tape Cartridge:	A reference cartridge selected as a standard for signal amplitude and reference field.
Standard Reference Amplitude:	The average peak-to-peak signal amplitude output of the Signal Amplitude Reference Cartridge when it is recorded on an NBS measurement system at the maximum flux density specified in this standard.
Streaming:	A method of recording on magnetic tape that maintains continuous tape motion without the requirement to start and stop within an interblock gap.
Track:	A longitudinal area on the tape along which a series of magnetic signals may be recorded.

Transition Cell:	The physical distance between two adjacent flux transition at the maximum recording density.
Transition Density or Physical Recording Density:	The number of recorded flux transitions per unit length of track, usually expressed in flux transitions per inch (ftpi) or flux transitions per millimeter (ftpmm). See also Data Density.
Underrun:	A condition developed when the host transmits or receives data at a rate less than required by the device for streaming operation.

3 REFERENCE EDGE

The Reference Edge shall be that edge of the tape which is nearest to the baseplate of the cartridge.

4 TRACK GEOMETRY

4.1 Track Positions

The position of the centre line of the reference burst of track 0 is referred to the Reference Edge. The positions of all the other even numbered tracks and track 1 are defined by specifying the distance of their centre lines from the centre line of the reference burst of track 0. The positions of all the other odd numbered tracks are defined by specifying the distance of their centre lines from the centre lines of the reference burst of track 1.

This standard supports Quick File Access (QFA). Track 25 shall be recorded in the forward direction if the tape is partitioned for QFA. A reference burst shall be recorded at the beginning of the track. Track 25 shall be recorded in the reverse direction without a reference burst if the tape is not partitioned for QFA. The location of track 25 is defined by referring to the center line of track 1 when QFA is not implemented and to the centerline of track 0 when QFA is implemented. See sections 4.3, and 6.3.

Figure 4.1 and table 4.1 shows track locations and positions for both formats.

4.2 Track Width

The width of the recorded track shall be:

0.00700 \pm 0.0050 in. (0.17780 \pm 0.0127 mm).

When writing, 0.00350 in \pm 0.0050 in. (0.08890 mm \pm 0.0127 mm.) of the recorded track shall be verified (Read-while-write with wide write/narrow read configuration).

4.3 Reference Bursts

On tracks 0, 1, 2, 3, 4, 5, 6, 7, 8, 9, 10, and 11 a reference burst shall be recorded prior to the normal data recording. When recorded in the forward direction track 25 shall also have a reference burst as shown in figure 4.1. This is further specified in section 6. The reference bursts on tracks 0 and 1 are recorded at a nominal frequency of 10 000 ftpi (394 ftpmm), while the other reference bursts are recorded with a nominal frequency of 20 000 ftpi (778 ftpmm).

4.4 Quick File Access

This standard supports Quick File Access (QFA). Tapes may either be recorded with partition for QFA or not.

With QFA implemented, this standard supports 2 partitions. The data (or default) partition is designated 0. It shall be recorded on all tracks except track 25. Partition 1 shall be the directory partition and shall be recorded on track 25 only. Track 25 shall then be recorded in the forward direction.

Tapes not partitioned for QFA shall have track 25 recorded in the reverse direction. Partition 1 shall be created through SCSI mode select (FDP).

Note: A QFA tape must be partitioned prior to any data recording.

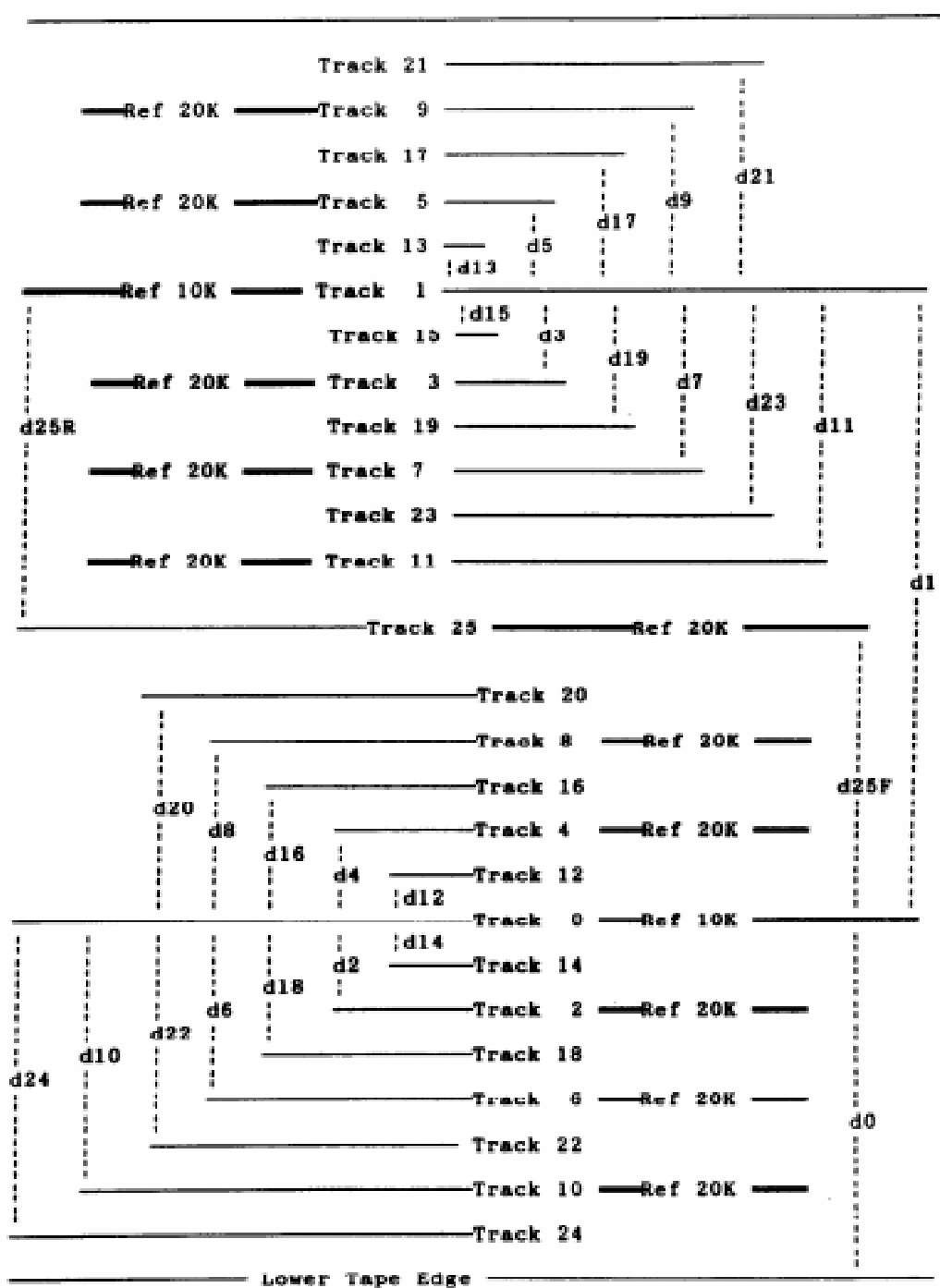

Figure 4.1 Track Location

Center line Positions when Writing						
	(Millimeters)			(Inches)		
d0=	1.803	±	0.051	0,0710	±	0.0020
d1=	3.061	±	0.051	0,1205	±	0.0020
d2=	-0.457	±	0.033	-0,0180	±	0.0013
d3=	-0.457	±	0.033	-0,0180	±	0.0013
d4=	0.457	±	0.033	0,0180	±	0.0013
d5=	0.457	±	0.033	0,0180	±	0.0013
d6=	-0.914	±	0.033	-0,0360	±	0.0013
d7=	-0.914	±	0.033	-0,0360	±	0.0013
d8=	0.914	±	0.033	0,0360	±	0.0013
d9=	0.914	±	0.033	0,0360	±	0.0013
d10=	-1.372	±	0.033	-0,0540	±	0.0013
d11=	-1.372	±	0.033	-0,0540	±	0.0013
d12=	0.229	±	0.033	0,0090	±	0.0013
d13=	0.229	±	0.033	0,0090	±	0.0013
d14=	-0.229	±	0.033	-0,0090	±	0.0013
d15=	-0.229	±	0.033	-0,0090	±	0.0013
d16=	0.686	±	0.033	0,0270	±	0.0013
d17=	0.686	±	0.033	0,0270	±	0.0013
d18=	-0.686	±	0.033	-0,0270	±	0.0013
d19=	-0.686	±	0.033	-0,0270	±	0.0013
d20=	1.143	±	0.033	0,0450	±	0.0013
d21=	1.143	±	0.033	0,0450	±	0.0013
d22=	-1.143	±	0.033	-0,0450	±	0.0013
d23=	-1.143	±	0.033	-0,0450	±	0.0013
d24=	-1.600	±	0.033	-0,0630	±	0.0013
d25R=	-1.600	±	0.033	-0,0630	±	0.0013
d25F=	1.372	±	0.033	0,0540	±	0.0013

The “-” sign indicates that the track is located below its corresponding reference track. Track 25 may be referenced to either track 1 (d25R) when recorded in reverse direction or to track 0 (d25F) when recorded in forward direction. The reference track for track 25 is only recorded when the track is recorded in the forward direction.

Table 4.1 Track Positions

5 RECORDING

5.1 Method of Recording

The recording method shall be the Non Return to Zero Mark (NRZ1) method where a ONE is represented by a change of direction of longitudinal magnetization.

5.2 Transition Densities

The nominal maximum transition density shall be 20 000 ftpi (787 ftpmm). The nominal transition cell length shall be 50 microinches (1.27 μm).

With the recording method used in this Standard, three transition densities may occur:

20 000 ftpi (787 ftpmm)
10 000 ftpi (394 ftpmm)
6667 ftpi (262 ftpmm)

5.3 Average Transition Cell Length Variations

5.3.1 Average Transition Cell Length

The average transition cell length is the sum of the distances between the flux transitions in n transition cells divided by $(n-1)$. The tests referred to below may be made in any continuously recorded pattern, provided the first and the last transition cell in the pattern each contain a flux transition.

5.3.2 Long Term Average Transition Cell Length

The long term average transition cell length is the average bit cell length taken over a minimum of 2000 000 transition cells. The long term average transition cell length shall be within $\pm 3\%$ of the nominal bit cell length.

5.3.3 Short Term Average Transition Cell Length

The short term average transition cell length is the average transition cell length taken over a minimum of 24 transition cells and a maximum of 32 transition cells. The short term average transition cell length shall be within $\pm 6\%$ of the long term average transition cell length.

5.3.4 Rate of Change of Transition Cell Length.

The rate of change of the transition cell length shall not exceed 0.25 %. The rate of change is given by the following relationship:

$$\text{Rate of Change: } \frac{\left| \frac{T1}{4} - \frac{T2}{4} \right|}{\frac{T3}{5}}$$

Where T1, T2 and T3 are the times between flux transitions as shown in figure 5.1. Periods 1 through 5 are contiguous and represent the repetitive encoding pattern 101010 within a data block, and frequency variations are less than 20 KHz.

Error! Objects cannot be created from editing field codes.

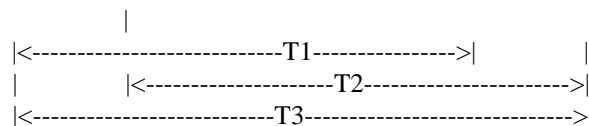

Figure 5.1 Rate of Change Test Pattern

5.3.5 Instantaneous Flux Transition Spacing

The instantaneous spacing between flux transitions is influenced by the reading and writing process, the pattern recorded (pulse-crowding effect) and other factors. Instantaneous spacings between flux transitions shall satisfy the following conditions:

In a sequence of flux transitions defined by the encoded pattern 11100111, the center flux transition of each group of 111's is called a reference flux transition. The maximum displacement of flux transitions on either side of the reference flux transitions shall not exceed +/- 28% of the transition cell length d_1 averaged over the five transition cells between the reference flux transitions indicated in the bit pattern in figure 5.2.

Error! Objects cannot be created from editing field codes.

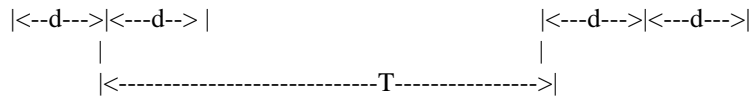

$$d_1 = T/5$$

$$d_1(1 - 0.28) < d < d_1(1 + 0.28)$$

Figure 5.2 *Test Pattern for Instantaneous Flux Transitions Spacing Test. X denotes a reference flux transitions.*

5.4 Signal Amplitude of a Recorded Cartridge for Data Interchange

When performing the tests described below, the output or resultant signal shall be measured on the same pass for both the Standard Amplitude Reference Cartridge and the tape under test. If possible, the measurements shall be performed during the write pass; if not during the first read pass after the write pass. The same equipment shall be used for all measurements. The signal amplitude shall be measured at a point in the read channel where the signal is proportional to the rate of change of the flux induced in the head.

After writing, the cartridge shall meet the following requirements:

5.4.1 Average Signal Amplitude at nominal maximum Density

At the nominal maximum physical recording density 20 000 ftpi (787 ftpmm), the Average Peak-to-Peak Signal Amplitude of any track on the interchange tape shall deviate no more than + 50% or - 35% from the Standard Reference Amplitude recorded at 20 000 ftpi (787 ftpmm). This averaging shall be made over the central 100 flux transitions of any 120 or more flux transitions recorded at nominal maximum density in a block and over at least 200 blocks.

5.4.2 Maximum Signal Amplitude

When interchanged, a tape shall not contain, in the valid information area, any flux transitions where the peak-to-peak signal amplitude is more than three times the Standard Reference Amplitude at 20 000 ftpi (787 ftpmm)

5.4.3 Minimum Signal Amplitude

When interchanged, a tape shall not contain, in its valid information area, any flux transitions where the peak-to-peak signal amplitude is less than 25% of the Standard Reference Amplitude at 20 000 ftpi (787 ftpmm).

5.5 Recorded Azimuth

On any track the angle that a flux transition across the track makes with a line perpendicular to the Reference B-plane of the cartridge shall not exceed 7 minutes of an arc (2.04 mrad).

5.6 Erasure

The magnetic tape shall be AC-erased prior to recording such that after the erasure any remaining signal amplitudes below twice the frequency corresponding to the maximum physical recording density shall be less than 3 % of the Standard Reference Amplitude at 20 000 ftpi (787 ftpmm).

When terminating a write operation on track 0, a minimum distance of 45 inches (1143 mm) shall be erased after the end of the recorded area. The whole distance between the end of the recorded area and the first EOT hole shall be erased if this distance is less than 45 inches (1143 mm).

6 USE OF TRACKS

6.1 Data Tracks

Each track shall be a data track and shall be written serially, one track at a time.

6.2 Track Numbering

All even numbered tracks shall be recorded in the forward direction (the direction from the BOT marker to the EOT marker). All odd numbered tracks shall be recorded in the reverse direction (the direction from the EOT marker to the BOT marker). If the Quick File Access option is implemented, track 29 shall be recorded in the forward direction.

6.3 Forward Reference Bursts

On Tracks 0, 2, 4, 6, 8, and 10 a Forward Reference Burst shall be recorded at the beginning of each of these tracks. The Reference Bursts on track 0 shall be recorded using a recording frequency of 10 000 ftpi (394 ftpmm), while the other Reference Bursts shall be recorded using a recording frequency of 20 000 ftpi (787 ftpmm). When recorded in the forward direction (QFA implemented) track 25 shall also be recorded with a reference burst as shown in figure 4.1.

These Forward Reference Bursts shall be written between the first BOT marker (the set of BOT holes closest to the LP hole) and the beginning of the recorded data area of the track. The Forward Reference Bursts shall start a minimum of 0 inches (0mm) and a maximum of 15 inches (381 mm) from the BOT marker, and shall extend past the LP marker for a minimum of 3 inches (76 mm) and maximum of 4 inches (101 mm).

There shall be no erased area between the end of any of the Forward Reference Bursts and the beginning of the preamble for the first data block on each of these tracks.

Except for the Forward Reference Bursts, there shall be no recorded signals between the first set of BOT holes and the LP marker on the lower half of the tape.

6.4 Reverse Reference Burst

For tracks 1, 3, 5, 7, 9, and 11 a Reverse Reference Burst shall be recorded between the first set of holes and the Early Warning holes. The Reverse Reference Burst shall be recorded while the tape is moving in the reverse direction.

The Reverse Reference Burst on track 1 shall be recorded using a recording frequency of 10 000 ftpi (394 ftpmm) while the other Reverse Reference Bursts shall be recorded using a recording frequency of 20 000 ftpi (787 ftpmm).

These Reverse Reference Bursts shall be written between the EOT marker and the beginning of the recorded data area on each of these tracks. These Reference Bursts shall start a minimum of 0 inches (0 mm) and a maximum of 15 inches (381 mm) from the EOT marker, and shall extend past the EW marker for a minimum of 3 inches (76 mm) and a maximum of 4 inches (101 mm). There shall be no erased area between the end of the Reverse Reference Bursts and the beginning of the preamble for the first data block on each track. The Reverse Reference Bursts for tracks 1, 3 and 5 will cross over the EW hole and therefore have a drop-out in this area.

Except for the Reverse Reference Burst, there shall be no recorded signals between the LP marker and the first set of BOT holes on the upper half of the tape.

6.5 Minimum/Maximum Distances, Even Tracks

On all even numbered tracks (0, 2, ... etc.) the beginning of the preamble of the first data block (or frame) shall commence a minimum distance of 3 inches (76 mm) and a maximum distance of 4 inches (101 mm) past the LP marker. On tracks with reference bursts, part of the reference burst will be overwritten by the preamble of the first block. On these tracks, no data shall be recorded beyond 36 inches (914 mm) past the EW marker. When recorded in the forward direction, track 25 shall also meet these requirements.

If QFA is implemented, track 25 shall also be recorded in the Forward direction in the same way as any even numbered track, with a reference burst at the beginning of the track.

On all even numbered tracks, no data shall be recorded beyond 36 inches (914 mm) past the EW marker. When recorded in the forward direction, track 25 shall also meet these requirements.

6.6 Minimum/Maximum Distances, Odd Tracks

On all odd numbered tracks (1, 3, ... etc.) the beginning of the first data block (or frame) shall commence a minimum distance of 3 inches (76 mm) and a maximum distance of 4 inches (101 mm) past the EW marker.

On odd numbered tracks 1, 3, 5, 13, 15 and 19 the valid data area shall terminate at most a distance of 4 inches (101 mm) and at least a distance of 0.1 inches (2.5 mm) before the LP marker, measured from the center of the LP hole. On the other odd tracks, no data shall be recorded beyond 27 inches (686 mm) past the LP marker.

6.7 Summary of Requirements

Table 6.1 and figures 6.1 on the next pages summarize the requirements in sections 6.1 to 6.6.

	Minimum	Maximum	Description
D1 D1	0 in. (0 mm)	15 in. (381 mm)	BOT or EOT to start of Reference Burst
D2 D2	3 in. (76 mm)	4 in. (101 mm)	LP or EW to start of valid data (or frame) area plus LP/EW to end of Reference Burst on tracks with Reference Burst
D3 D3	- -	36 in. (914 mm)	EW to End of Data on even tracks.
D4 D4	- -	27 in. (686 mm)	LP to end of data on all odd tracks except tracks 1,3,5,13,15 and 19
D5 D5	0.1 in. (2.5 mm)	4 in. (101 mm)	End of data to LP on tracks 1,3,5,13,15 and 19

Table 6.1 Summary of Requirements for Use of Tracks.

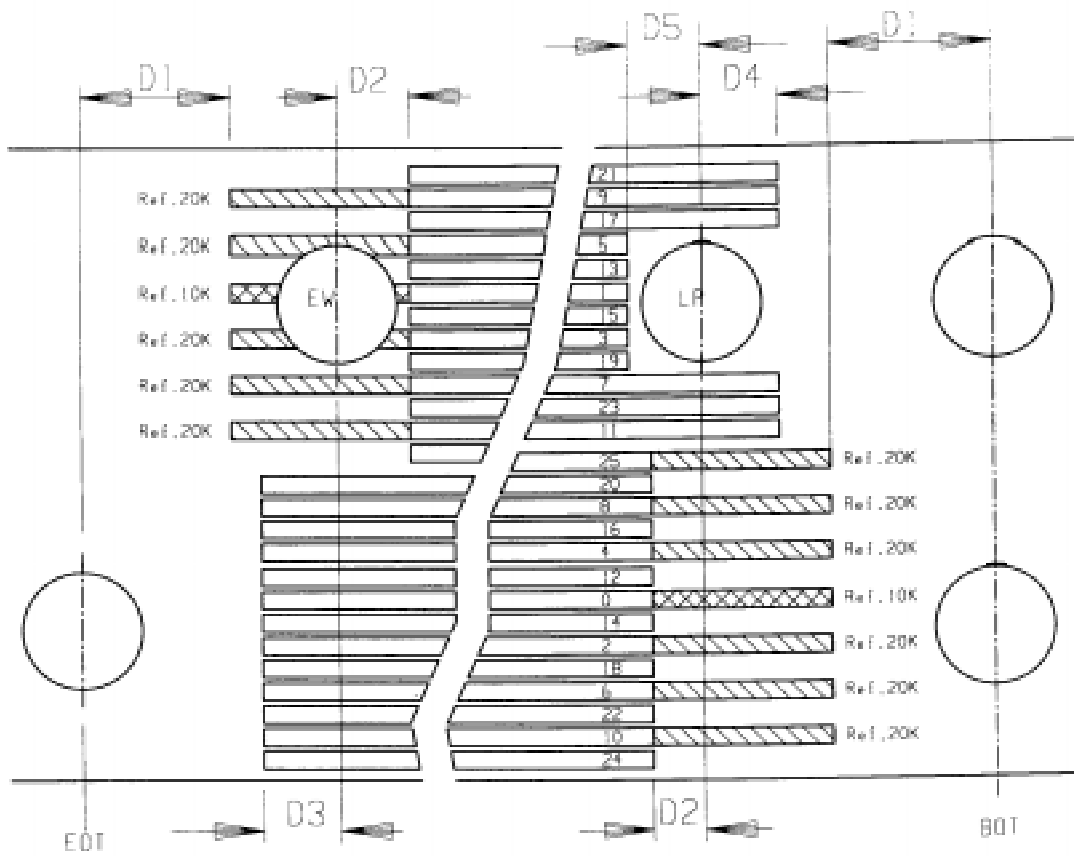

Figure 6.1 Requirements for Use of Tracks.

7 BYTE AND CODE REQUIREMENTS

7.1 Byte Length

The data shall be in eight-bit bytes. The 8 bits in each byte are numbered b0 to b7, b7 being the most significant bit.

7.2 Code

Bits b0 to b6 correspond to the 7 least significant bit assignments specified in the American National Standard Code for Information Interchange (ASCII), ANSI X3.4 - 1986. To comply with this standard, bit 7 shall always be set to Zero and the seven bits b0 through b6 shall represent ASCII characters.

Upon agreement between the interchange parties, other coded character sets may be used. Bit 7 may then be a Zero or a One depending upon the character standards used.

8 TRANSFORMING OF CODED CHARACTERS PRIOR TO RECORDING ON THE TAPE

Prior to the recording of the data on the tape, the coded character representation as described in section 7 shall be transformed into a encoded bit pattern according to table 8.1 (GCR 4,5 code). Unless otherwise indicated in the description of the tape format, all bytes to be recorded shall be transformed using this table prior to the recording.

The encoded information shall then be recorded as described in section 6.

Each 8-bit byte shall be split into two groups of four consecutive bits, one group containing the four most-significant bits (b7 to b4) and one group containing the four least-significant bits (b3 to b0). Each 4-bit group shall then be transformed into a 5-bit group according to table 8.1.

For each encoded byte, the most significant bit shall be recorded first. Consequently, the 5-bit group corresponding to data bits b7 to b4 shall be recorded first, starting with encoded bit e4. When this group is recorded the least significant group corresponding to data bits b3 to b0 shall follow, again starting with encoded bit e4.

The most significant data bit is always to the left in the table. This encoding will give a minimum of zero and a maximum of two "0" 's between two ONE's.

Data Bits				Encoded Bits				
b7	b6	b5	b4	e4	e3	e2	e1	e0
b3	b2	b1	b0					
0	0	0	0	1	1	0	0	1
0	0	0	1	1	1	0	1	1
0	0	1	0	1	0	0	1	0
0	0	1	1	1	0	0	1	1
0	1	0	0	1	1	1	0	1
0	1	0	1	1	0	1	0	1
0	1	1	0	1	0	1	1	0
0	1	1	1	1	0	1	1	1
1	0	0	0	1	1	0	1	0
1	0	0	1	0	1	0	0	1
1	0	1	0	0	1	0	1	0
1	0	1	1	0	1	0	1	1
1	1	0	0	1	1	1	1	0
1	1	0	1	0	1	1	0	1
1	1	1	0	0	1	1	1	0
1	1	1	1	0	1	1	1	1

Table 8.1 Encoding Table.

9 TRACK FORMAT

9.1 FRAMES

9.1.1 General Information

Each track is divided into frames as shown in figure 9.1. Each frame contains 16 blocks (data blocks, information blocks (File Marks, identifier or filler blocks, or ECC blocks). Each block is numbered sequentially, starting with 0 for the first block on track 0, and then incremented by one for each new block, regardless of track number. Frames are numbered indirectly, by using the 16 most significant bits of the Block Address.

Frame N	Frame N+1	Frame N+2	Frame N+3	Frame N+4	Frame N+5	Frame N+6
---------	-----------	-----------	-----------	-----------	-----------	-----------

Figure 9.1 General Track Layout.

The frame operation is controlled by the recording drive and the whole frame system shall be invisible from the host side. The purpose for the use of frames is to control the error correction operation.

Once recorded, a frame shall not be overwritten or partly erased by new frames. A frame which cannot be completed on one track shall be completed at the beginning of the next track.

The number of blocks within a frame is always fixed. Each frame shall contain 14 Data/Information Blocks and two ECC (Error Correction Control) blocks plus any rewritten bad blocks.

Each block contains 1024 data or information bytes.

The first frame contains only QIC-525 Identifier Blocks (plus the two ECC blocks).

9.1.2 Frame Layout.

The general layout of a frame is shown in figure 9.2.

Data Block 0	Data Block 1	Data Block 12	Data Block 13	ECC Block 14	Ecc Block 15
--------------	--------------	-------	---------------	---------------	--------------	--------------

Figure 9.2 General Frame Layout.

Any block determined as bad during the Read-While-Write verification is rewritten immediately at the end of the second following block. See section 9.4.

9.2 Block types

There are 7 different types of blocks:

- Data Block
- ECC Block
- Cancel Block (option)
- Identifier Block
- File Mark Block
- Set Mark Block
- Filler Block

Information in the Control Field determines the type of block being recorded. See tables 9.5.

The Data Field of the blocks contains always 1024 bytes, although the number of valid data bytes in the block may be less than 1024. See section 9.5.

Information about how many user data bytes that are available in each data block is recorded in the Control Field of the block.

9.2.1 Data Block

The Data Block contains user data. A full Data Block contains 1024 bytes, but variable data blocks may contain from 1 to 1023 valid data bytes (see section 9.5).

9.2.2 QIC-525 Identifier Block

The IDENTIFIER Block is generated by the drive only. All 14 Data/ Information blocks in frame 0 (the ID frame) are QIC-525 Identifier blocks.

The Identifier blocks are generally invisible to the host system, but may optionally contain information in the data area which may be transferred to the host by special commands.

This Standard specifies the use of the first 9 Identifier blocks as follows:

Option 1 does not specify the contents of the data area of any the Identifier blocks. It may be used to record special cendor unique information, as long as it does not come in conflict with the requirements described in Option 2.

Option 2 specifies the use of the first 9 Identifier blocks as follows

(In this section, several references are made to QIC-121. However, this Standard does not require that a drive recording a format containing option 2 as described below shall be fully compatible with QIC-121).

9.2.2.1 Identifier Block 0

The contents of the first block in the ID frame (Identifier Block 0) is not specified except for the first 16 bytes. These bytes shall contain the following information:

The first 8 bytes shall contain the KEY that determine whether the information in the next 8 blocks meet this specification or not. These 8 bytes shall contain the ASCII code for the characters "QIC-525" as shown in figure 9.3.

The next 8 bytes shall identify the WRITING DRIVE MANUFACTURER in accordance with table J-1 of the X3T9-2 SCSI-2 VENDOR IDENTIFICATION list.

The complete layout for block 0 of the ID frame is shown in figure 9.4.

	BYTES							
	0	1	2	3	4	5	6	7
ASCII char.	Q	I	C	-	5	2	5	
Hex. Value	51	49	43	2D	32	47	42	20

Figure 9.3 Layout of first 8 bytes of Block 0 in ID frame.

First 8 Bytes	Next 8 Bytes	1008 Bytes
KEY	Manufacturers ID	Not Defined

Figure 9.4 Layout of Block 0 in ID frame.

9.2.2.2 Identifier Block 1

The first 512 bytes of the data area of Identifier block 1 shall contain Inquiry Data exactly as it would be reported by the drive in response to an Inquiry command. The Inquiry Data shall at least include the Standard Inquiry Data List, located from byte 0 of the data area up to maximum byte 511. The remaining 512 bytes of the data area in this block may be utilized by each vendor. The use of these bytes is not a part of this standard.

The format of the Inquiry Data recorded in the first 512 bytes of the block shall be as specified in table 9.1. Unused bytes (that is unused bytes covered by the Additional Length field) shall be filled with the ASCII code for the blank character.

The Peripheral Device Type shall always be set to 01_{hex}. The RMB bit shall be set to one. For further information, see QIC-121.

Byte #	Bits							
	7	6	5	4	3	2	1	0
0	Peripheral Qualifier				Peripheral Device Type			
1	RMB	Reserved						
2	ISO Version		ECMA Version			ANSI-Approved Version		
3	AENC	TrmIQP	Reserved		Response Data Format			
4	Additional Length (n-4)							
5	Reserved							
6	Reserved							
7	RelAdr	WBus32	WBus16	Sync	Linked	Res.	CmdQue	SftRe
8	(MSB)							
.	. Vendor Identification							
.	.							
15	(LSB)							
16	(MSB)							
.	. Product Identification							
.	.							
31	(LSB)							
32	(MSB)							
.	. Product Revision Level							
.	.							
35	(LSB)							
36	(MSB)							
.	. Vendor Specific							
.	.							
55	(LSB)							
56	(MSB)							
.	. Reserved							
.	.							
95	(LSB)							
96	Vendor-Specific							
.	Parameter Bytes							
.								
511								

Table 9.1 Inquiry Data Format

9.2.2.3 Identifier Block 2

The data area of Identifier block 2 shall contain MODE SENSE data. It shall be set up as if an implicit MODE SENSE command has been executed where the returned data is moved into the first 512 bytes of the data area of Identifier block 2 (and not to the SCSI bus as usual). This data shall be formatted as shown in figure 9.5.

Byte 0: Header List
Block Descriptor List
Page Descriptor Lists in ascending order of Page Code
Last 512 Data Bytes Unspecified

Figure 9.5 Layout of Identifier Block 2.

Only the first 512 bytes of the data area of Identifier Block 2 are allocated for mode sense data. Unused portion of this area shall be filled with blank characters. The remaining 512 bytes of the data area are unspecified.

Header List

This is the standard MODE SENSE Header List from QIC-121 and shown in table 9.2. Note that the first part of the Header List (the Mode Sense Data Length) is set to specify the total length of the following sense data including all Page Descriptor Lists. The Medium Type field shall indicate the current cartridge type. The Write Protect (WP) bit shall be set to zero. The Speed field shall be set to zero. The Block Descriptor Length shall be set to 8 to indicate that a single Block Descriptor List follows next. See QIC-121 table 7-61 for further details.

Byte #	Bits							
	7	6	5	4	3	2	1	0
0	Mode Sense Data Length							
1	Medium Type							
2	WP	Buffered Mode			Speed			
3	Block Descriptor Length							

Table 9.2 Header List

Block Descriptor List

This is the standard MODE SENSE Block Descriptor List shown in table 9.3. The Density Code shall be set to xx_{hex} to indicate that the current tape format is QIC-1000. See QIC-121 table 7-63 for further details.

Byte #	Bits							
	7	6	5	4	3	2	1	0
0	Density Code							
1	(MSB)							
.	Number of Blocks							
3	(LSB)							
4	Reserved							
5	(MSB)							
.	Block Length							
7	(LSB)							

Table 9.3 Block Descriptor List

Page Descriptor Lists

The various Page Descriptor Lists supported by the device follows in ascending order of page code. They shall be formatted according to table 9.4. See QIC-121 table 7-64 for further details.

Byte #	Bits							
	7	6	5	4	3	2	1	0
0	PS	Reserv	Page Code					
1	Page Length							
2 → n	Mode Parameters							

Table 9.4 Page Descriptor List.

9.2.2.4 Identifier Blocks 3 and 4

The data area of block 3 and 4 are reserved for additional mode data. Only the first 512 bytes of each block may contain valid information.

9.2.2.5 Identifier Block 5

The data area of Identifier block 5 shall be reserved for Vital Product Data. If Vital Product Data are recorded this block shall at least include the Supported Vital Product Data Page. See figure 9.6 This page shall start at byte 0 in the data area of Identifier block 5 and may be followed by other VPD pages in ascending order of Page Code. A maximum of 512 bytes can be allocated for VPD data. Unused bytes shall be filled with blank characters. The remaining 512 bytes are unspecified. The format of the Vital Product Data pages shall be as specified in QIC-121 (tables 7-76 and 7-77 and related text).

Byte 0: Summary of Supported Pages (VPD Identifier 00h)
Vital Product Data Pages in ascending order of Page Code
Last 512 Data Bytes Unspecified

Figure 9.6 Layout of Identifier Block 5.

If any Vital Product Data is included the first VPD page shall be the Supported Product Data Page (VPD Page Code 00h). This page holds a list of VPD Page Codes for the VPD pages to follow. The format of this page is specified in table 7-76 in QIC-121.

Vital Product Data Pages

Vital Product Data Pages are appended in ascending order of VPD code. The format of these pages shall be as specified in QIC-121.

9.2.2.6 Identifier Blocks 6, 7 and 8

The data area of blocks 6, 7 and 8 shall be reserved for diagnostic data at the discretion of the drive manufacturer.

The contents of Identifier blocks 9 - 13 is not specified.

9.2.2.7 Reading Out Identifier Block Information

See Appendix A for a description of how the data in the ID frame may be transferred to the host.

9.2.3 File Mark Block

The File Mark Block is a block designated as a File Mark. Normally, the Data Area of a File Mark block contains no valid information, however, it may optionally be used for special host File Mark information. This is not specified in this Standard.

9.2.4 Filler Block

A filler block contains no valid information in the data area.

9.2.5 ECC Block

The ECC Block contains error correction parity bytes which may be used during a subsequent read operation where one or more data blocks cannot be read correctly.

9.2.6 Setmark Block

The Setmark Block is a block designated as a Setmark (see QIC-121 for a logical definition). Normally, the data area of a Setmark contains no valid information, however, it may optionally be used for special host File Mark information. This use is not specified in this standard.

9.2.7 Cancel Mark Block (Optional)

The Cancel Mark Block is a block designated as a Cancel Mark. The Cancel Mark may only be recorded (appended) logically directly after *two logically consecutive File Marks at End of Recorded Area (End of File)*. Logically it operates as a "negative" File Mark; i.e. One File Mark followed by one Cancel Mark is zero (File Mark not reported).

Prior to the recording of the Cancel Mark, the drive shall verify that the two File Marks are recorded consecutively (from a logical point of view), that they both are valid and that they are recorded at End of Recorded Area (End of File). Only one Cancel Mark (with rewrites if required) shall be recorded in conjunction with these two File Marks.

A recorded tape may contain several groups of two File Marks and one Cancel Mark as a combination, however each of these Cancel Marks shall have been recorded in an independent append operation, meeting the requirements above.

Cancel Marks shall never be reported to the host.

Physically, Filler blocks may be recorded between the File Marks and the Cancel Mark or between the File Marks or both. See also Appendix B.

Cancel Blocks are optional in this Standard. Drives that has not implemented this feature shall ignore all cancel marks completely.

NOTE:

Some drives made according to revisions A, B, C and D of this standard will not be able to correctly read tapes recorded with one or more Cancel Marks. It is recommended that the Cancel Mark option is only used if the recorded tape shall be read by drives made according to revision E or higher of this standard.

9.3 BLOCK FORMAT

9.3.1 General Layout

All blocks have the same basic layout as shown in Figure 9.7:



Figure 9.7 Layout of a block

All sections of a block are recorded continuously without any erased gaps between the sections. All blocks within a frame are also always recorded continuously without any erased interblock gaps. Frames are also recorded continuously, except during append operations. During this operation, a short area with erased or damaged recording may occur between the end of the postamble of one frame and the preamble of the next frame due to the write current turn on time. This area shall always be shorter than the length of the recording of one byte of data.

9.3.2 Preamble

The preamble consists of a fixed pattern of all ONE's recorded at the highest nominal frequency. The length of the preamble varies, but the contents is always the same: ...1111111111..... The preamble shall be used to synchronize the phase locked loop or a similar circuit to the frequency and the phase of the data signal. It shall also be used to measure the average signal amplitude.

To achieve maximum capacity it is recommended to use the minimum specified preamble length wherever feasible.

There are three different types of preamble: NORMAL, ELONGATED and LONG.

A **Normal** Preamble shall contain a minimum of 400 and a maximum of 600 transitions recorded at the highest nominal frequency (20 000 ftpi/787 ftpmm).

This preamble shall be recorded at the beginning of each block, except for the first block in a frame append operation.

An **Elongated** Preamble shall contain a minimum of 8800 and a maximum of 13 600 transitions recorded at the highest nominal frequency (20 000 ftpi/787 ftpmm). It shall be recorded at the beginning of the first block in a frame which is appended to already existing data on a track and the first block in a frame after an underrun situation.

An **Long** Preamble shall contain a minimum of 24 000 and a maximum of 36 000 transitions recorded at the highest nominal frequency (20 000 ftpi/787 ftpmm).

This preamble shall be recorded at the beginning of the first block on every track, even if the block is in the middle of a frame.

9.3.3 Block Marker

The Block Marker marks the start of a new frame or block. It contains 10 encoded bits in a unique pattern not found in any data field:

11111 00111

The left bit is the most significant bit, recorded first.

9.3.4 Data Field

The Data Field contains 1024 bytes of data, encoded according to the rules in section 8. The contents of the data field depends upon the type of block being recorded:

* Data Block:	All 1024 bytes are available for user data.
* QIC-525 Identifier Block	May contain valid host or vendor unique information in its data field. See 9.2.2.
* File Mark/Setmark Block:	Contains no valid information in its data field. May contain vendor unique information.
* Filler Block:	Contains no valid data.
* Cancel Mark Block	Contains no valid data.
* ECC Block:	Contains error correction characters generated by the drive.

9.3.5 Control Field

All blocks have 4 bytes in their control field, as shown in figure 9.8. Control bytes 0-2 are always used for address and track information, regardless of block type, while the use of control byte 3 depends upon the block type being recorded.

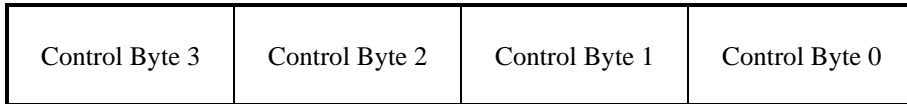

Figure 9.8 Layout of Control Field.

Byte 3 is recorded first followed by Control Byte 2 and so on. All bytes are encoded according to the rules given in section 8.

Figure 9.9 shows the layout of Control Byte 3.

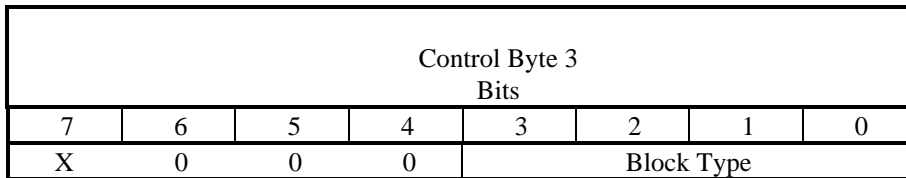

Figure 9.9 Layout of Control Byte 3.

Bits 6, 5 and 4 of Control Byte 3 are reserved and shall always be set to 0.

Bit 7 of Control Byte 3 may either be set to 0 (permanently) or optionally used to indicate blocks recorded past Logical Early Warning. When set to 1, Early Warning condition is indicated. When set to 0, the absence of Early Warning condition is indicated. This is an optional feature. Drives which do not implement this feature shall always set this bit to zero.

The four least significant bits of Control Byte 3 is used to indicate the type of block being recorded. The coding of these four bits is shown in table 9.5. All combinations of the four control bits 0-3 not specified in table 9.5 are reserved. Drives meeting this Standard shall ignore (skip) all reserved combinations in order to minimize compatibility problems with future updates of this Standard.

Variable blocks are treated in detail in section 9.5.

Control Byte 3 is the only control byte covered by ECC protection.

The layout of Control Bytes 0-2 is shown in figure 9.10.

Except for the 4 most significant bits of control byte 2, the other 20 bits are a part of the physical block address as specified in figures 9.10. This block address is independent of block type and track numbers. It starts with 00000_{Hex} for the first block on track 0, and is incremented by one for each new block being recorded.

Rewritten blocks keep their original block number. The block numbering is not reset at the start of a new track.

Control Byte 3 Bits 3 2 1 0	Block Type	Comments
0 0 0 0	<i>Full Data Block End Variable Host Block</i>	This block contains 1024 bytes of valid data. A variable host block containing an integer number of 1024 bytes of data (1024, 2048, 3078 etc.) ends with this block.
0 0 0 1	<i>Full Data Block Partial Variable Host Block</i>	This block contains 1024 bytes of valid data. This block and the next valid block on the tape are part of a variable host block.
0 0 1 0	<i>Full Data Block QIC-02 Compatible</i>	This block contains 1024 bytes of valid data, which consists of two host data blocks (each containing 512 data bytes).
0 1 0 0	<i>Variable Data Block 1- 255 data bytes. End Variable Host Block.</i>	This block contains from 1 to 255 bytes of valid data. A host variable block ends with this block if the rest number of data bytes in the host block is between 1 and 255 (see section 9.5)
0 1 0 1	<i>Variable Data Block 256 - 511 data bytes. End Variable Host Block.</i>	This block contains from 256 to 511 bytes of valid data. A host variable block ends with this block if the rest number of data bytes in the host block is between 256 and 511 (see section 9.5)
0 1 1 0	<i>Variable Data Block 512 - 767 data bytes. End Variable Host Block.</i>	This block contains from 512 to 767 bytes of valid data. A host variable block ends with this block if the rest number of data bytes in the host block is between 512 and 767 (see section 9.5)
0 1 1 1	<i>Variable Data Block 768 - 1023 data bytes. End Variable Host Block.</i>	This block contains from 768 to 1023 bytes of valid data. A host variable block ends with this block if the rest number of data bytes in the host block is between 768 and 1023 (see section 9.5)
1 0 0 0	<i>File Mark</i>	No valid information in data area.
1 0 0 1	<i>Filler Block</i>	No valid information in data area.
1 0 1 0	<i>QIC525 Identifier Block</i>	May contain valid information in data area.
1 1 0 0	<i>Setmark</i>	No valid information in data area.
1 1 1 1	<i>Cancel Mark</i>	Optional Block. No valid information in data area.

Table 9.5 Encoding of Block Type Control Bits.

The four most significant bits of control byte 2 contains a track address. This track address is the physical track number as specified in section 4 divided by 2. Thus tracks 0 and 1 both have track address 0, tracks 2 and 3 have address 1 and so on. This track address always follows the physical track number. If a frame cannot be completed at the end of tracks 1, 3, 5 etc., the track address must be incremented by one before writing the remaining blocks in the frame on the next track.

Control Bytes 0-3 are encoded according to the rules in section 8. Byte 3 is recorded first, followed by byte 2 and so on. The most significant encoded bit in each byte is recorded first.

Control Byte 2		Control Byte 1		Control Byte 0	
Bits 7 6 5 4	Bits 3 2 1 0	Bits 7 6 5 4	Bits 3 2 1 0	Bits 7 6 5 4	Bits 3 2 1 0
Track Address	Part of Physical Address (20 bits)				

Figure 9.10 Layout of Control Bytes 0-2.

9.3.6 CRC FIELD

The CRC (Cyclic Redundancy Check) field consists of 4 bytes calculated over the whole data block area and control field area, starting with the most significant bit of byte 0 in the Data Field and ending with the least significant bit of Control Byte 0 in the Control Field. All calculations are done prior to the data encoding. All 32 bits in the CRC character shall be set to ONE prior to the start of the CRC calculation. The generating polynomial shall be:

$$x^{32} + x^{28} + x^{26} + x^{19} + x^{17} + x^{10} + x^6 + x^2 + 1$$

The four bytes shall be encoded according to the rules in section 8 prior to the recording. The most significant byte shall be recorded first.

9.3.7 Postamble

The postamble consists of a fixed pattern of all ONE's recorded at the highest nominal frequency. The length of the postamble varies, but the contents is always the same:

...1111111111.....

The Postamble is recorded at the end of each block following the CRC bytes.

There are two different types of postambles:

NORMAL and ELONGATED.

A **Normal** Postamble shall contain a minimum of 10 and a maximum of 20 flux transitions recorded at the nominal maximum flux density of 20 000 ftpi (787 ftpmm). This postamble shall be recorded at the end of each block, except for the last block in frame when an underrun situation has occurred.

After writing this normal postamble, the following preamble shall be recorded so that there is no phase shift or transition glitches between the end of this postamble and the beginning of the next preamble.

An **Elongated** Postamble shall contain a minimum of 8 800 and a maximum of 13 600 flux transitions recorded at the nominal highest flux density of 20 000 ftpi (787 ftpmm). This postamble shall be recorded at the end of the block if an underrun situation has occurred, or at the end of the last block in a recording.

9.4 Block Rewrites

Any block determined to be bad during the read-while-write verify operation shall be re-recorded immediately after the next block.

Each block may be re-recorded up to 16 times after the previous block has been determined good. Figure 9.11 shows typical formats resulting from rewrite operations.

Blocks being rewritten shall be identical to the original blocks with the same block address, data contents etc. The only thing which may be changed is the track address if the rewriting takes place on the next (even) track. During read operation, two or more good blocks with the same block address may therefore be detected by the drive. Should this happen, the drive shall use the data contents of any of these valid blocks.

When a block is determined bad, the rewrite operation shall not begin before the write operation of the following block is finished. However, the following block does not have to be completely verified before the bad block is rewritten.

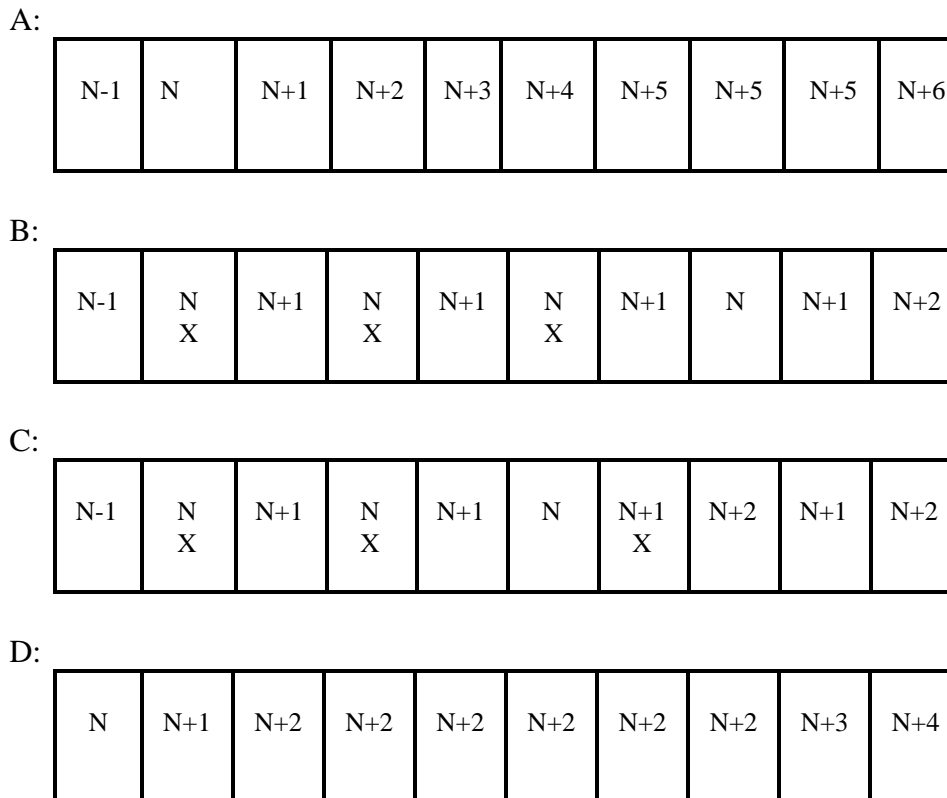

Figure 9.11 Examples of possible format layout variations due to block rewrite operations. X denotes a bad block. Z denotes a bad block either due to a purposely recorded incorrect CRC value, or to a purposely truncated block. Figure 9.11D shows format after forced streaming operation.

A correct block N shall be followed, not necessarily immediately, by a correct block N+1. When counting the number of rewrites for a block N+1, only those following a verified block N shall be counted.

This rewrite scheme is independent of frames. Therefore, the writing of the first blocks in the next frame may begin before the last block in the previous frame has been completely verified.

It is allowed to rewrite consecutive blocks with the same block number as shown in figure 9.11D (forced streaming). This may be done to prevent termination of a streaming operation due to an underrun situation. The forced streaming mode shall always be performed with the last block and terminated when the next block is available or at the end of file or end of track.

9.5 Fixed and variable blocks

This standard allows for the recording of both fixed and variable host blocks. The physical blocks recorded on the tape contain always 1024 data bytes, however, some of these data bytes may not be valid in every block.

9.5.1 Fixed Host Blocks, 1024 Data Bytes

In this case, the host block size is the same as the size of the physical recorded block. The lower nibble of Control Byte 3 will be set to 0_{Hex} and all data bytes in the recorded block are valid.

9.5.2 Fixed Host Blocks, QIC-02 Compatible

In this case, the physical recorded block contains 1024 valid data bytes, however, it is transferred to the host as **two** data blocks containing 512 data bytes each in order to be compatible with the QIC-02 interface specification. The lower nibble of Control Byte 3 will be set to 2_{Hex}.

9.5.3 Variable Host Blocks, < 1024 Data Bytes

In this case, the physical recorded data block contains less than 1024 valid data bytes. The layout of the data field is shown in figure 9.12.

Data Field 1024 Bytes		
Valid Data Bytes	Filler Bytes Unspecified	Valid Data Counter (Byte 1023)

Figure 9.12 Layout of Data Field, Physical Variable Data Blocks.

The number of valid data bytes are specified by bits 0 and 1 in Control Byte 3 (see table 9.5) and the value of the last byte in the data field, byte 1023. This byte contains a number from 1 to FF_{Hex} (255_{Dec}) depending upon the number of valid data bytes. The valid data bytes are always recorded first in the data field, then come filler bytes (no value specified in this standard) and finally as the last byte the Valid Byte Counter.

A variable block containing 392 bytes of valid data will therefore be recorded with the lower nibble of Control Byte 3 set to 5_{Hex} and byte 1023 of the data field set to 88_{Hex} (136_{Dec}).

9.5.4 Variable Host Blocks, > 1024 Data Bytes

In this case, the host block is recorded as one or more Full Data Block, Partial Host Block (the lower nibble of Control Byte 3 = 1_{Hex}) plus either one Variable Block (lower nibble of Control Byte 3 = either 4_{Hex}, 5_{Hex}, 6_{Hex} or 7_{Hex}) or one Full Data Block, End Variable Host Block (lower nibble of Control Byte 3 = 0_{Hex}).

The number of remaining valid data bytes in the variable host block when all the full data blocks have been recorded, determines the size of the variable block.

Example 1:

Variable host block size is 4096 bytes. This will be recorded as shown in figure 9.13.

Variable Host Block, 4096 Data Bytes			
Block No. N	Block No. N+1	Block No. N+2	Block No. N+3
Full Data Block	Full Data Block	Full Data Block	Full Block End
Partial Variable Host Block	Partial Variable Host Block	Partial Variable Host Block	End Variable Host Block
Control Byte 3 is 01Hex	Control Byte 3 is 01Hex	Control Byte 3 is 01Hex	Control Byte 3 is 00Hex

Figure 9.13 Variable Host Block, 4096 Bytes.

Example 2:

Variable host block size is 2051 bytes. This will be recorded as shown in figure 9.14.

Variable Host Block, 2051 Data Bytes		
Block No. N	Block No. N+1	Block No. N+2
Full Data Block	Full Data Block	Variable Data Block 1 - 255 Data Bytes
Partial Variable Host Block	Partial Variable Host Block	End Variable Host Block Control Byte 3 is 04Hex
Control Byte 3 is 01Hex	Control Byte 3 is 01Hex	Last byte in data field is 03 Hex (2051 - 1024 - 1024 = 3)

Figure 9.14 Variable Host Block, 2051 Data Bytes.

Example 3:

Variable host block size is 1673 bytes. This will be recorded as shown in figure 9.15.

Variable Host Block, 1673 Data Bytes	
Block No. N+1	Block No. N+1
Full Data Block	Variable Data Block 512 - 767 Data Bytes
Partial Variable Host Block	End Variable Host Block Control Byte 3 is 06Hex
Control Byte 3 is 01Hex	Last byte in data field is 89 Hex (= 137 Decimal) (1673 - 1024 - 256 -256 = 137)

Figure 9.15 Variable Host Block, 1673 Data Bytes.

9.6 Append Operation

The last block recorded on the tape is always terminated with an Elongated Postamble (see section 9.3.7). If new data shall be appended to the already existing data on the tape, the first new block shall be recorded with an Elongated Preamble (see section 9.3.2). The append operation shall be performed so that the postamble of the previous block and the preamble of the new block overlaps as shown in figure 9.16. The recording in the overlap area may not be readable by the drive.

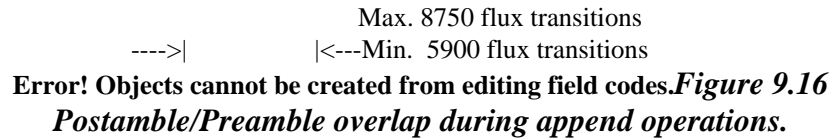

A minimum of 5900 flux transitions and a maximum of 8750 flux transitions of the previously recorded postamble shall remain intact (not overwritten) when the preamble for the next block is recorded. The overlap area will then have a minimum length equivalent to 50 flux transitions and a maximum length equivalent to 7700 flux transitions. The minimum available preamble area for synchronization will be 1100 flux transitions.

9.7 DATA COMPRESSION

This Standard supports data compression as an optional feature. More than one method of data compression may be employed.

It is not a requirement in this Standard that the drive must support data compression to be compatible with the Standard. The Standard is designed such that drives that do support the general QIC-525 and QIC-121 Standards but do not support data compression will be able to retrieve compressed data and transfer it to the host.

The rules for data compression are set forth below. The user should also refer to the QIC-121 for additional information.

9.9.1 General Rules

The data on the directory partition of a QFA tape shall not be compressed.

Only the data area in the data blocks may contain compressed data. All other information is uncompressed. Other blocks and tape marks shall be uncompressed.

If compression is enabled, all data blocks within current partition shall be grouped into Compression Block Groups (except the directory partition, which shall be written uncompressed).

9.9.2 Compression Block Group

Compressed data will be grouped into Compression Block Groups. The Compression Block Group shall contain a ten bytes Compression Header as described below. The first data byte following the Compression Header is the beginning of compression and the last byte is the end of compressed data. The Compression Block Group shall be limited to 32 K (32768) bytes of uncompressed data. Each Compression Block Group shall be written to the tape as one variable logical block.

9.9.3 Data Compression with Fixed or Same Sized Blocks

When writing in fixed block mode, a number of same sized blocks may be grouped, compressed and recorded as one Compression Block Group on the tape.

9.9.4 Data Compression with Variable Blocks

When writing in variable block mode, each write data command is recorded as one or more Compression Block Groups. Variable blocks having a transfer length greater than 32 K (32768) bytes shall be divided into multiple Compression Block Groups. Each Compression Block Group shall not contain data from more than one write command.

9.9.5 Compression Header

The Compression Header consist of 10 bytes of uncompressed data placed at the beginning of each Compression Block Group. It shall be the first 10 bytes in the data field representing the Compression Block Group. These 10 bytes shall be uncompressed with the following layout:

Byte 0	UCMP	BCLB	ECLB	Header length
Byte 1	QIC compression algorithm ID			
Byte 2	Uncompressed logical block length MSB			
Byte 3	Uncompressed logical block length LSB			
Byte 4	Uncompressed logical block quantity MSB			
Byte 5	Uncompressed logical block quantity LSB			
Byte 6	Logical block number MSB			
Byte 7	Logical block number NMSB			
Byte 8	Logical block number NLSB			
Byte 9	Logical block number LSB			

UCMP (bit 7)	Uncompressed. This bit will indicate that the data in the Compression Block Group is uncompressed. NOTE: This bit will be set if the DCE-bit (Data Compression Enable) is set and the 'Compression Algorithm'-field is set to zero in the MODE SELECT, Data Compression Parameter Page.
BCLB (bit 6)	Beginning of Compression Logical Block. This bit is set if the Compression Block Group is the first or the only Compression Block Group in the Compressed Logical Block.
ECLB (bit 5)	End of Compression Logical Block. This bit is set if the Compression Block Group is the last or the only Compression Block Group in the Compressed Logical Block.
Header Length (bits 4 to 0)	The size of the header. This field will always be 0Ah.
QIC Compression Algorithm	The registered compression algorithm identifier. Refer to QIC-121 for additional details.
Uncompressed Logical Block Length	Contains the size in bytes of the host defined (fixed) logical blocks in the Compression Block Group, or the transfer length in bytes of the host variable block.
Uncompressed Logical Block Quantity	Contains the number of host blocks compressed and recorded on the tape as one compressed variable block. This number is '1' if the host operates with variable blocks. Hence, the number '1' may also indicate that one, and only one, fixed block resides in the Compression Block Group.
Logical Block Number	Contains the logical address of the first block in the Compression Block Group. If a logical block is represented by multiple Compression Block Groups, The Logical Block Number will be the same for all the Compression Block Groups which represent the logical block.

The total number of uncompressed bytes within one Compression Block Group is given by multiplying the 'Uncompressed Logical Block Length' and the 'Uncompressed Logical Block Quantity'.

When writing and reading compressed data, the Compression Block Groups are not visible for the user. The Compression Header will not be transferred to the host during decompression. If a tape which contains compressed data is read on a drive without data decompression, the complete Compression Block Group with the Compression Header *and* the compressed data will be transferred to the host. The host must then use the information in the Compression Header to decompress the data.

Example:

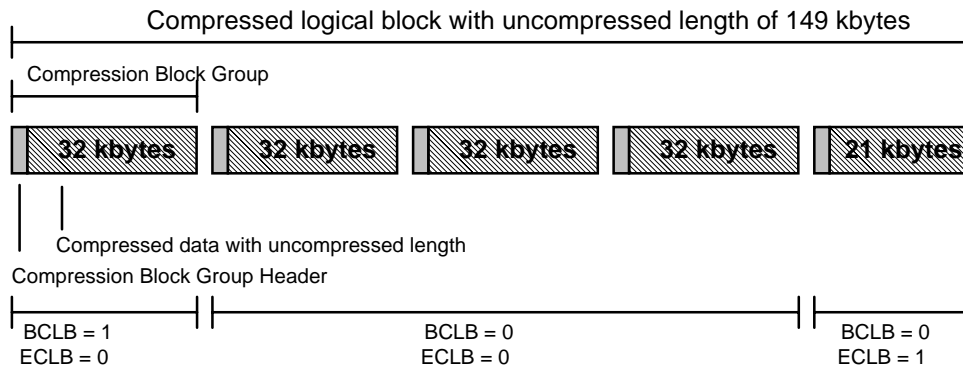

9.9.6 Configuration of drive for datacompression

According to QIC-121 MODEpage 0Fh shall be used to select compression or decompression algorithm. The user should refer to QIC-121 for more details. As a reference, Appendix C shows the proposed implementation of this compression page.

10 ERROR CORRECTION

The ECC blocks at the end of each frame may be used during the data read operation to reconstruct blocks in error.

The error correction system makes it possible to correct 2 blocks with CRC errors within each frame.

10.1 Error Correction Matrix Format

A frame contains 16 blocks, 14 data blocks and two ECC parity blocks. Each block contains 1024 data bytes and 1 Control Byte (Control Byte 3) which are covered by ECC control. The bytes in ECC frame are considered to be arranged in 16 blocks (rows) by 1025 bytes as shown in figure 10.2. The ECC parity bytes shall be chosen so that each column of the matrix forms an independent Reed-Solomon codeword of redundancy two, with 8-bit characters, as shown in figures 10.2.

10.2 Field Representation

GF(256) is the field consisting of 256 elements. Each field element "a" has the form

$$a = a_7x^7 + a_6x^6 + a_5x^5 + a_4x^4 + a_3x^3 + a_2x^2 + a_1x + a_0.$$

where each a_i is either 0 or 1. A field element "a" shall be represented by a byte as shown in figure 10.1.

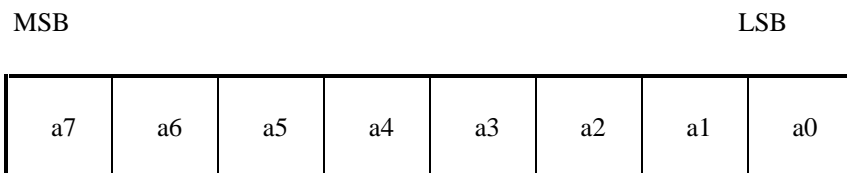

Figure 10.1 Bit Numbering Convention

Field math operations (addition, multiplication, division) are defined to be polynomial math modulo an irreducible binary polynomial of degree eight, $f(x)$, where binary addition is the logical exclusive-or operation and binary multiplication is the AND operation. The irreducible polynomial used to generate the field GF(256) shall be:

$$f(x) = x^8 + x^7 + x^2 + x + 1 .$$

COLUMNS

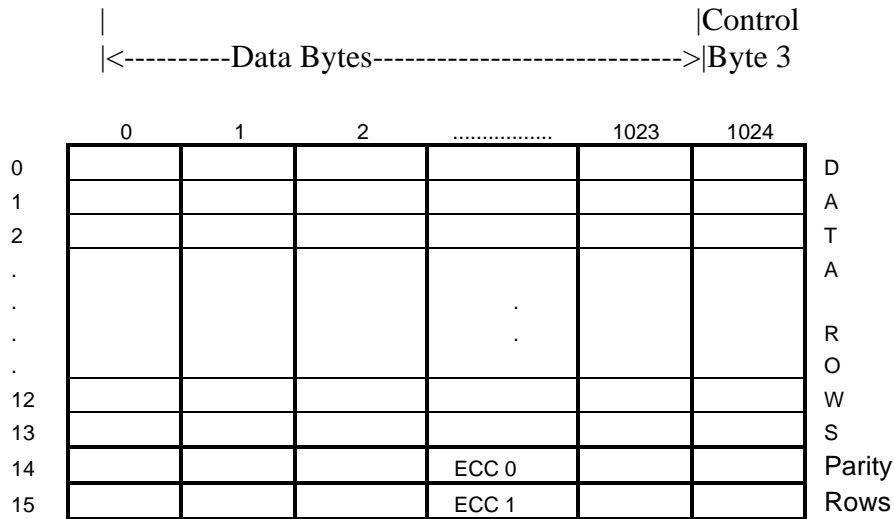

Figure 10.2 ECC Frame Format

10.3 Code Generator Polynomial

The generator polynomial for the Reed-Solomon code is of the form

$$g(x) = x^2 + ax + b,$$

where a and b are field elements. However, a and b are not arbitrary. They must be chosen so that the roots of g(x) over the field are consecutive powers of a primitive element of the field (e.g. a root of f(x)).

There are eight roots of f(x) in GF(256), so let r be one of them. Then g(x) will have the form:

$$g(x) = (x + r^0)(x + r^1) = (x+1)(x+2) = x^2 + 3x + 2$$

with r=2.

To encode a column of data, label the data bytes in a given column by their row number, as in figure 10.2, from d₀ to d₁₃. Encoding a frame shall be accomplished as follows. In a frame, each column contains data bytes d₀ to d₁₅, numbered as in figure 10.2. The parity bytes d₁₄ and d₁₅ in each column shall be chosen so that the polynomial

$$d(x) = \sum_{i=0}^{15} d_{15-i}x^i$$

(Σ = SUM)

is divisible by g(x), using polynomial division over the field GF(256). In practice, encoding is done by taking the remainder using a linear feedback shift register.

10.4 Example Codewords

The following columns of bytes are codewords for the polynomials defined in the preceding sections, using hex notation for the field elements.

Row							
0	:	00	00	00	00	00	
...							
11	:	00	00	00	00	00	
12	:	00	00	01	02	04	07
13	:	01	10	00	04	08	0C
14	:	03	30	07	02	04	01
15	:	02	20	06	04	08	0A

Table 10.1 Example of Codewords.

APPENDIX A

The data found in the Identifier blocks 1, 2 and 5 may optionally be transferred to the Initiator by using the INQUIRY and MODE SENSE commands.

Inquiry Data

When the Identifier Frame of a QIC-525 tape have been read the Inquiry data from Identifier block 1 and 5 can be transferred to the Initiator by using a the INQUIRY command with RIB (Read Information Block) bit set to one. The INQUIRY command shall then transfer Inquiry data and VPD data as usual except that the data returned is taken from the Identifier Frame of the tape and not from the device itself.

The RIB bit is located in bit 7 byte 5 of the INQUIRY command descriptor block.

If no Identifier Frame have been read (from the currently inserted tape), then an INQUIRY command with the RIB bit set to one shall be terminated with CHECK CONDITION status. The Sense Key shall be set to ILLEGAL REQUEST with the ASC byte = 14 hex and ASCQ byte = 00 to indicate RECORDED ENTITY NOT FOUND.

Mode Sense Data

When the Identifier Frame of a QIC-525 tape have been read the mode sense data from Identifier block 2 can be transferred to the Initiator by using a the MODE SENSE command with RIB (Read Information Block) bit set to one. The MODE SENSE command shall then transfer mode sense data as usual except that the data returned is taken from the Identifier Frame of the tape and not from the device itself.

The RIB bit is located in bit 7 byte 5 of the MODE SENSE command descriptor block.

When the RIB bit is set to one the PC (Page Control) field of the MODE SENSE command shall be ignored.

If no Identifier Frame have been read (from the currently inserted tape), then a MODE SENSE command with the RIB bit set to one shall be terminated with CHECK CONDITION status. The Sense Key shall be set to ILLEGAL REQUEST with the ASC byte = 14 hex and ASCQ = 00 to indicate RECORDED ENTITY NOT FOUND.

APPENDIX B

Cancel Mark (option)

Many tape control systems developed for 1/2" 9-track tape drives used the principle of writing two File Marks at the end of last file recorded on the tape to indicate end of data. When appending data on such tapes, the second File Mark is first erased to remove the end of data indicator. This is shown in figure B-1.

First Write Operation:

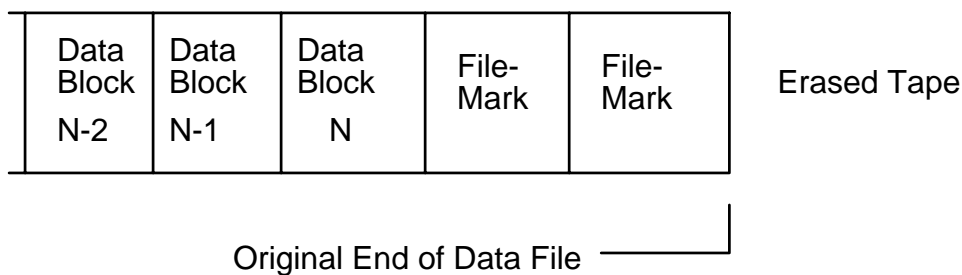

Same Area after Append Operation:

Physical and Logical Layout:

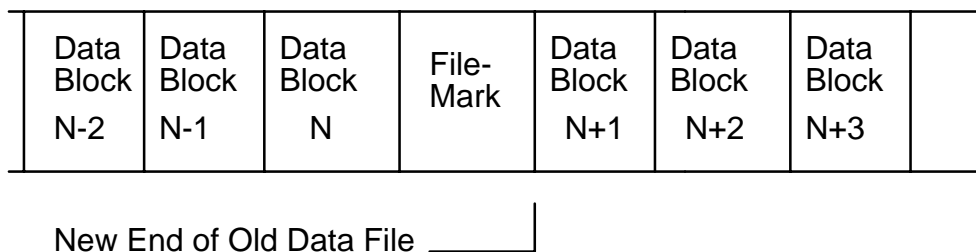

Figure B-1 Append operations, 1/2" tape formats.

A QIC-525 compatible tape drive cannot perform this operation as overwrite is not specified in the format standard. The Cancel Mark option offers the same flexibility without any overwrite requirements. This optional feature makes it possible for QIC-525 compatible drives to better emulate a 1/2" tape drive system.

The Cancel Mark block acts as a "negative" File Mark. When a Cancel Block follows directly after two consecutive File Marks, the drive when reading the tape shall logically ignore the last File Mark and the companion Cancel Mark.

Except in the case of "killing" the last File Mark as described above, the Cancel Mark has no other function and shall never be reported back to the host.

Figure B-2 shows the use of the Cancel Mark.

First Write Operation:

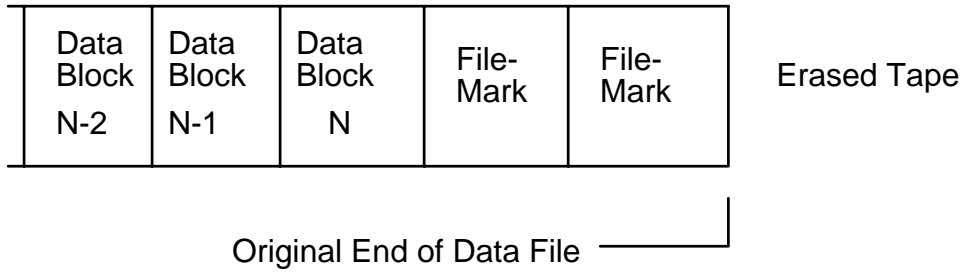

Same Area after Append Operation:

Physical Layout:

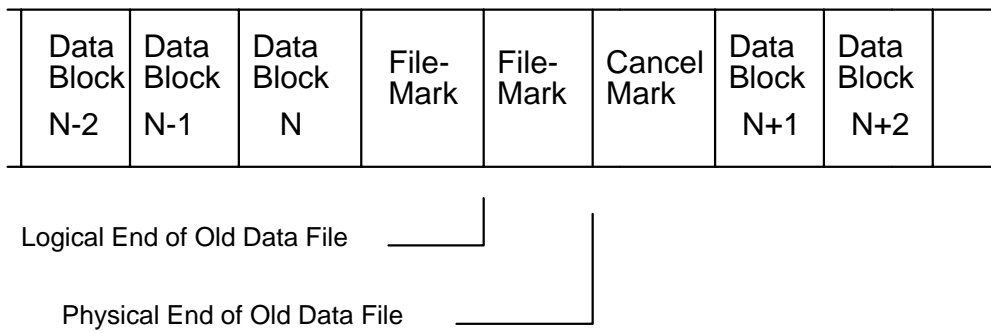

Logical Layout:

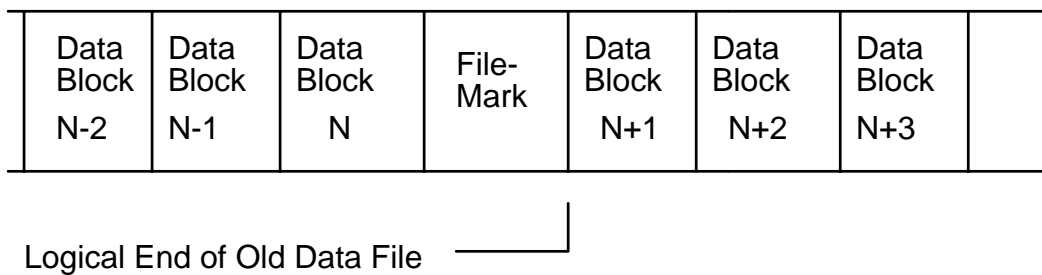

Figure B-2 Append operations with optional Cancel Mark.

The Cancel Mark shall always be appended as the logically first block after the second consecutive File Mark. It is not allowed to write a Cancel Mark unless the two logically preceding blocks are File Mark Blocks. The drive must also verify both File Marks as "good", and it must also verify that the two File Marks are at the End-of-Recorded Area before a Cancel Mark may be appended.

No Cancel Marks shall be recorded if the preceding File Mark group consists of three or more logically consecutive File Marks.

(Filler Blocks are acceptable, either after the two File Marks or between the two File Marks or both, as they in this tape format are logically non-existent. Therefore, a drive may terminate a write operation with two consecutive File Marks and one or more Filler Blocks and still according to this Standard start an append operation later by first writing a Cancel Mark after the last Filler Block).

Only one Cancel Mark is allowed for each group of two consecutive File Marks, however, the Cancel Mark may be rerecorded several times in order to meet the read-while-write verification requirements.

The data area of the Cancel Mark Block contains no valid data according to this Standard.

.....

This optional feature may be activated by emulating a ½" command sequence used to overwrite the last File Mark at EOR (EOF) as follows:

Space to EOR (End of Recorded Area)
Space Reverse one File Mark
Write Data

It is also possible to implement this feature via the SCSI bus using the Mode Select command. For SCSI-I and SCSI-II, the following command may be used:

SCSI-I:
Vendor Unique Page,
Byte 13,
Bit 2 (named EOWR).

SCSI-II:
Miscellaneous Parameter Page
Page Code 20
Byte 08,
Bit 4 (named EOWR)

EOWR = Enable Overwrite

NOTE:

Some drives made according to revisions A, B, C and D of this standard will not be able to correctly read tapes recorded with one or more Cancel Marks. It is recommended that the Cancel Mark option is only used if the recorded tape shall be read by drives made according to Revision E or higher of this standard.